

FOLDGUARD  
FOLDING MACHINE SAFETY  
& GUARDING SYSTEM

# Operation Manual

LS-CS-M-077



**Performance without compromise.™**

[lazersafe.com](http://lazersafe.com)

📍 27 Action Road, Malaga WA 6090, Australia

✉ PO Box 2368, Malaga WA 6944, Australia

☎ +61 8 9249 4388

📠 +61 8 9249 6011

✉ [info@lazersafe.com](mailto:info@lazersafe.com)

## Document Status

---

Document Reference Code: LS-CS-M-077  
Version: 1.06  
Released: 03/09/2021

## Document Revision History

---

Date	Manual Version	Software Version	Summary of Change
10/06/2015	1.00		New Manual
21/09/2015	1.01		General corrections, updates.
17/02/2017	1.02		Updated User Interface Panel information screen. Updated start-up sequence. Added SAM forced after 3 strokes. Added clamp over travel limit. General corrections.
19/07/2017	1.03		Updated Copyright notice. Revised Maintenance section. Minor corrections.
23/01/2018	1.04		Updated overtravel description. Minor corrections.
05/06/2020	1.05	HMI 2.00.03 App. HMI__201	Updated Copyright Information. Modified for LZS-2-FG laser guards. Updated alignment images. Added Section 2.3.5, UL General Safety Compliance. Minor corrections, formatting.
03/09/2021	1.06	HMI 2.00.07 App. HMI__208	Updated Copyright Information. Minor corrections. Added light curtain auto/manual mode. Updated number of Bending Apron inputs. Updated software versions.

## Copyright Information

---

“Lazer Safe”, “Press Control Safety System”, “PCSS”, “PCSS-A”, “LZS-LG”, “LZS-LG-HS”, “LZS-004”, “LZS-004-HS”, “LZS-1”, “LZS-2”, “LZS-2-FG”, “LZS-R”, “LZS-XL”, “LZS-005”, “IRIS”, “IRIS Plus”, “RapidBend”, “RapidBend Plus”, “RapidBend Ultimate”, “FlexSpeed”, “FlexSpeed Plus”, “SmartLink”, “BendShield”, “BendShield Plus”, “AutoSense”, “AutoSense Plus”, “AutoSense Ultimate”, “BullRoarer”, “Sentinel”, “Sentinel Plus”, “Defender”, “Defender Plus”, “FoldGuard”, “PressGuard” and “LazerGuard” are trademarks of Lazer Safe Pty Ltd.

ISaGRAF is a registered trademark of Rockwell Automation, Inc.

Microsoft and Windows are either registered trademarks or trademarks of Microsoft Corporation in the U.S.A. and / or other countries.

The content of this manual is supplied for informational use only, is subject to change without notice and should not be construed as a commitment by Lazer Safe Pty Ltd. Lazer Safe Pty Ltd assumes no responsibility or liability for any errors, inaccuracies or omissions that may appear within this publication.

Copyright in this documentation is owned by Lazer Safe Pty Ltd. No part of this document may be reproduced or copied in any form or by any means (graphic, electronic, or mechanical including photocopying, recording, taping, or information storage and retrieval systems) without the written permission of Lazer Safe Pty Ltd.

Lazer Safe’s copyright in this document is protected by Australian copyright laws (including the Copyright Act 1948 (Commonwealth)) and by international copyright treaties.

© 2021 Lazer Safe Pty Ltd. All rights reserved.

# Table of Contents

<b>1</b>	<b>About This Manual .....</b>	<b>1</b>
1.1	Document Objectives.....	1
1.2	Technical Competence Requirements.....	1
1.3	Prerequisites .....	1
1.4	Document Organisation .....	1
1.5	Related Documentation.....	2
1.6	Guide to Notes, Cautions and Warnings .....	2
1.7	Obtaining Technical Assistance.....	2
<b>2</b>	<b>Critical Safety Information .....</b>	<b>3</b>
2.1	Proper Use of FoldGuard .....	3
2.2	Special Warnings .....	3
2.3	Regulatory Requirements for Use .....	4
2.3.1	Requirements For Factory Fitted Systems-Within The European Union.....	4
2.3.2	Requirements For Factory Fitted Systems-Outside The European Union.....	4
2.3.3	Requirements For Retrofitted Systems-All Locations .....	4
2.3.4	Equipment Alterations .....	4
2.3.5	UL General Safety Compliance .....	4
<b>3</b>	<b>System Overview .....</b>	<b>5</b>
3.1	Key Benefits.....	5
3.2	System Components .....	6
3.3	Optical Protection Overview .....	6
3.3.1	Laser Classification and Warnings.....	7
3.3.2	Laser Transmitter and Receiver Setup .....	7
3.3.3	Mute Point .....	8
3.4	Normal Mode .....	9
3.4.1	Obstruction Detection – From a Stationary Position .....	9
3.4.2	Obstruction Detection - When the Clamp is Closing .....	9
3.5	Hemming Mode .....	10
3.5.1	First Stroke in Hemming Mode .....	10
3.5.2	Operating in Hemming Mode.....	10
3.6	Field Muted Mode .....	11
3.7	Safety Stop Mode .....	11
3.8	Bending Apron Mode .....	11
3.9	Emergency Stop Inputs.....	12
3.10	No Guard / No Counter Mode .....	12
3.11	Closed Loop Design .....	12
<b>4</b>	<b>Transmitter and Receiver Alignment .....</b>	<b>13</b>
<b>5</b>	<b>The FoldGuard User Interface Panel.....</b>	<b>14</b>
5.1	User Interface Overview .....	14
5.2	Error Reset Indicator and Reset Button .....	15

5.3	Mute Indicator.....	15
5.4	The Main Screen .....	15
5.4.1	Status and Action Windows.....	16
5.4.2	Main Screen Button Labels.....	16
5.4.3	Sensor Window .....	16
5.5	Mode Select Screen .....	17
5.6	Menu Screen .....	18
5.6.1	User Guides .....	19
5.7	Info Screen .....	19
5.7.1	System Information .....	20
5.7.2	Machine Information .....	20
<b>6</b>	<b>System Operation.....</b>	<b>21</b>
6.1	Power-up .....	21
6.2	Start-up Test.....	21
6.3	Setting the Mute Point .....	22
6.4	Resetting the Mute Point.....	24
6.5	Selecting Hemming Mode.....	25
6.6	Selecting Field Muted Mode.....	26
6.6.1	Exiting Field Muted Mode.....	27
6.7	Selecting Safety Stop Mode .....	27
6.7.1	Exiting Safety Stop Mode .....	28
6.8	Jorns Twinmatic - Automatic Light Curtain Switching .....	29
6.8.1	System Start-up .....	29
6.8.2	Automatic Switching Function .....	29
<b>7</b>	<b>User and Supervisor Menus .....</b>	<b>30</b>
7.1.1	Selecting Menu Parameters.....	31
7.1.2	Setting Option Parameters .....	32
7.1.3	Setting Numeric Parameters.....	32
7.2	User Menu .....	33
7.2.1	Parameter 0 – Buzzer On/Off .....	33
7.3	Supervisor Menu .....	33
7.3.1	Parameter 0 – Supervisor Access Code .....	33
7.3.2	Parameter 1 – Field Muted Button Functionality .....	34
7.3.3	Parameter 2 – Safety Stop Button Functionality.....	34
7.3.4	Parameter 3 – Safety Distance .....	34
7.3.5	Parameter 4 – Language.....	34
<b>8</b>	<b>Operator Instruction and Demonstration .....</b>	<b>36</b>
8.1	Equipment Identification .....	36
8.2	Starting the System .....	36
8.3	Slow Speed Operation.....	36
8.4	Mute Point Setting .....	37

8.5	Operation in Normal Mode .....	37
8.6	Hemming Mode .....	37
8.7	Field Muted Mode .....	37
8.8	Safety Stop Mode .....	38
8.9	Setting the Laser Position.....	38
8.10	Running the System .....	38
8.11	Customer Sign Off – Training Completed .....	39
<b>9</b>	<b>Maintenance.....</b>	<b>40</b>
9.1	Transmitter & Receiver .....	40
<b>10</b>	<b>Glossary of Terms .....</b>	<b>41</b>

# 1 About This Manual

---

This chapter contains information about this manual, containing the following elements:

- Document Objectives.
- Technical Competence Requirements.
- Prerequisites.
- Document Organisation.
- Related Documentation.
- Guide to Notes, Cautions and Warnings.
- Obtaining Technical Assistance.

## 1.1 Document Objectives

This manual provides information about the configuration and operation of the FoldGuard Folding Machine Guarding System.

## 1.2 Technical Competence Requirements

This manual has been written for the use of trained and competent personnel as defined below.

- Any engineer who is responsible for the planning, design and construction of automatic equipment using FoldGuard should be of a competent nature, trained to and qualified in all relevant local and national standards required to fulfil that role. Such engineers should be fully conversant in all aspects of safety with regards to automatic equipment.
- Any commissioning or service engineer must be of a competent nature, trained to and qualified in all relevant local and national standards required to fulfil that role. Such engineers should also be trained in the use and maintenance of the completed product, including being completely familiar with all associated documentation. All maintenance should be carried out in accordance with established safety practices.
- All operators of the installed equipment should be trained to use it in a manner that complies with established safety practices. Operators should also be familiar with all documentation concerning operation of the equipment.

## 1.3 Prerequisites

To use the **Lazer Safe FoldGuard Folding Machine Safety and Guarding System Operation Manual**, you should be fully conversant with all critical safety aspects of the Lazer Safe laser guarding system, and the folding machine upon which it is to be installed.

## 1.4 Document Organisation

This manual is organised into the following chapters:

1. About This Manual (this chapter).
2. Critical Safety Information.
3. System Overview.
4. Transmitter and Receiver Alignment.
5. The FoldGuard User Interface Panel.
6. System Operation.
7. User and Supervisor Menus.
8. Operator Instruction and Demonstration.
9. Maintenance.
10. Glossary of Terms.



## 1.5 Related Documentation

This manual should be used in conjunction with the following documents:

- The operating manual for your folding machine.
- Lazer Safe FoldGuard Folding Machine Safety and Guarding System Installation Manual (LS-CS-M-078).
- Lazer Safe FoldGuard Folding Machine Guarding System Alignment Guide (LS-CS-M-051).

## 1.6 Guide to Notes, Cautions and Warnings



**Note:**

This symbol indicates helpful information that helps you make better use of your Lazer Safe product.



**Caution:**

This symbol alerts you to situations that could result in equipment damage.



**Warning:**

This symbol indicates danger. You are in a situation that could cause bodily injury. Before you work on any equipment, be aware of the hazards involved with electrical circuitry and be familiar with standard practices for preventing accidents. To see translations of the warnings that appear in this publication, refer to the translated safety warnings that accompanied this device.

## 1.7 Obtaining Technical Assistance

For technical support with the FoldGuard system, please contact your supplier or email [customerservice@lazersafe.com](mailto:customerservice@lazersafe.com) detailing your specific requirement.

## 2 Critical Safety Information

### 2.1 Proper Use of FoldGuard

FoldGuard is designed to protect hands and fingers in the area close to the edge of the clamping area. When installed correctly and when safety instructions are observed fully, the FoldGuard system permits safe manipulation close to the clamp, as well as offering effective protection while the clamp closes at high speed.

Please note these general safety notices:

- The FoldGuard system is designed exclusively for installation and operation on hydraulic folding machines, or folding machines that comply with the statutory machine safety and accident prevention rules and regulations valid for the place where the folding machine is operated, in particular after FoldGuard has been installed.
- FoldGuard must be installed either in the folding machine factory, or by specialist technicians trained by Lazer Safe (or its authorised representatives).
- The operator must be fully conversant with the operation of the folding machine and the risks associated with it, as well as the operation of the FoldGuard guarding system.
- The alignment of the protective equipment should be performed by a maintenance engineer, supervisor or personnel with equivalent specialist expertise trained in all relevant aspects of operating the folding machine and the FoldGuard guarding system.
- Suitable protective equipment must be worn by the operator at all times.

### 2.2 Special Warnings

To ensure the highest possible degree of safety in operating a folding machine fitted with FoldGuard, it is important to note the following special warnings.



#### **Warning: SLOW SPEED OPERATION**

Under certain circumstances FoldGuard will initiate slow speed.

**However, some folding machines are not capable of changing the closing speed of the clamp to slow speed. FoldGuard will allow the clamp to close at normal operating speed, but will always perform a safety stop before the clamp closes.**

The operator will have to release and press the foot pedal again to complete the clamping operation.



#### **Warning: AVOID FAST, ERRATIC MOVEMENTS AS CLAMP CLOSSES**

When the clamp closes at high speed (above mute point) there will be less than maximum protection at the point prior to the clamp reaching the mute point. For example, if a small obstruction, such as a finger, is rapidly and erratically pushed into the clamp area immediately before the mute point, the finger might be touched.



#### **Warning: NO PROTECTION IN FIELD MUTED MODE**

In Field Muted mode, the optical sensing is deactivated. Although FoldGuard engages the slow speed signal and forces a safety stop on each cycle, particular caution must still be exercised.

**The ability to select Field Muted mode is disabled by default, and can only be enabled by personnel who have access to the Supervisor menu of the HMI. This menu is password protected and should only be accessible to suitably trained and qualified personnel.**



#### **Warning: NO PROTECTION BELOW SAFETY STOP POSITION**

Under certain circumstances the FoldGuard system will initiate a safety stop, and

stop the clamp at the safety height (programmed in the System menu, refer **Section 7.3.4**).

**When the foot pedal is released and pressed again the clamp will close with the optical protection disabled. Particular caution must be exercised below the safety stop position.**

## 2.3 Regulatory Requirements for Use

FoldGuard can be used only on hydraulic folding machines, or folding machines deemed by relevant regulatory authorities to have equivalent functional and dynamic characteristics.

Different regulatory requirements apply to the use of the FoldGuard system depending upon whether it has been factory-fitted to a new folding machine, or retrofitted to a folding machine already in operation.

### 2.3.1 Requirements For Factory Fitted Systems-Within The European Union

The combination of a folding machine and FoldGuard must:

- Have been type-approved by a Notified Body and
- Comply with the respective local rules and regulations in regard to machine safety and accident prevention.

### 2.3.2 Requirements For Factory Fitted Systems-Outside The European Union

The combination of a folding machine and FoldGuard must comply with the relevant local regulations that apply to machine safety and accident prevention.

### 2.3.3 Requirements For Retrofitted Systems-All Locations

The combination of a folding machine and FoldGuard must comply with the relevant local regulations that apply to machine safety and accident prevention. It must also receive any other approvals that may be required by the regulations governing the operation of machinery at the location where the machine is being used.

### 2.3.4 Equipment Alterations

Any alterations to the examined and certified combination of protective equipment and machine are likely to void relevant approvals and certifications. Such alterations may include the integration of the machine into a robot system, or the connection of the machine to an electronic data bus system.

Similarly, any alteration of the FoldGuard system, or its bridging, or both, either in part or full is expressly prohibited.

Access to the electrical equipment cases of the machine control unit and the components within them is restricted to personnel trained and authorised for this purpose by Lazer Safe.

### 2.3.5 UL General Safety Compliance

The PGS-2 Safety Controller is UL approved, please refer to the Lazer Safe file **NRAQ.E514131** on the UL database for details (registration required).

<https://www.ul.com/apps/product-ig>

Note that the PGS-2 has been evaluated for UL General Safety compliance only; the software functionality, reliability and the safety features were not evaluated by UL.

## 3 System Overview

FoldGuard is specifically designed for folding machine applications. It provides a complete safety solution including optical guarding of the clamping operation, overrun monitoring and management of additional machine safety components.

FoldGuard can be installed on a folding machine during manufacture (OEM FoldGuard) or installed on machines already operating (Retrofit FoldGuard). This manual applies to both systems, and where necessary any differences between the operation of the OEM and Retrofit systems will be highlighted.



**Note:**

The OEM version of FoldGuard may be embedded with the folding machine controller, and can be customised to suit the OEMs specific operational requirements. In this case the operating sequence of FoldGuard may differ from that described in this manual.

Please contact the manufacturer of your folding machine for operating manuals or guides specific to your machine.

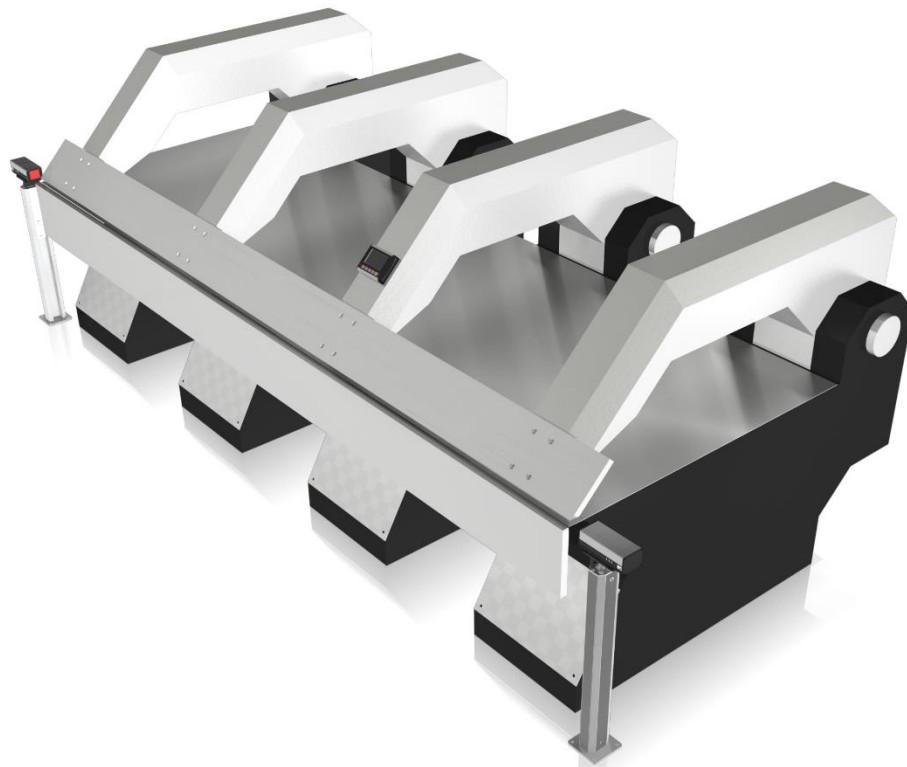

**Figure 3-1: Folding Machine with FoldGuard**

### 3.1 Key Benefits

- FoldGuard provides laser guarding of the clamping area for improved safety and productivity. Dual flat bands of continuous laser light detect obstructions as small as 4mm, while remaining vibration tolerant.
- FoldGuard continuously monitors the stopping distance in real time.
- The 6mm mute point is set on the first clamping. The laser sensors detect the clamp position, and the operator confirms the mute point.
- The operator can configure FoldGuard to allow hemming operations while still guarding the clamping area.
- FoldGuard provides a complete guarding solution also monitoring operator safety switches such as emergency stop pushbuttons and kick bars.

## 3.2 System Components

The system contains the following components:

- LZS-2-FG Laser Transmitter/Receiver pair.
- Lazer Safe Safety Controller.
- FoldGuard User Interface Panel.
- Optical Rotary Encoder.
- Floor mounting bracket system for the LZS-2-FG Transmitter and Receiver.

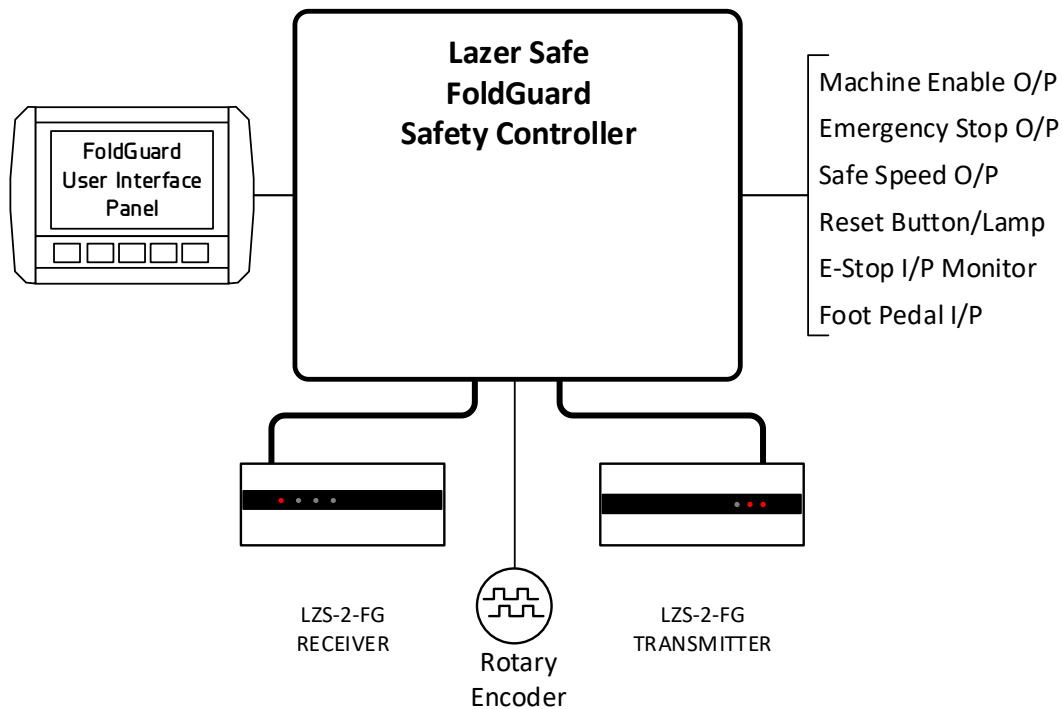

Figure 3-2: FoldGuard Folding Machine Guarding System Components

## 3.3 Optical Protection Overview

FoldGuard features the LZS-2-FG Block Laser Transmitter/Receiver pair, which provides optical protection along the entire length of the clamping area. As the clamp closes in high speed the system monitors the area between the clamp and material. If any foreign obstruction (tools, operator's fingers etc.) is detected, the clamp closing movement is immediately stopped. The clamp will not make contact with the obstruction. During normal operation the block laser is always active.

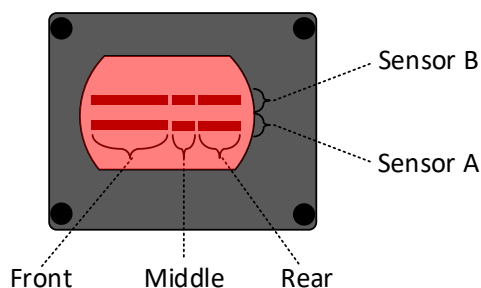
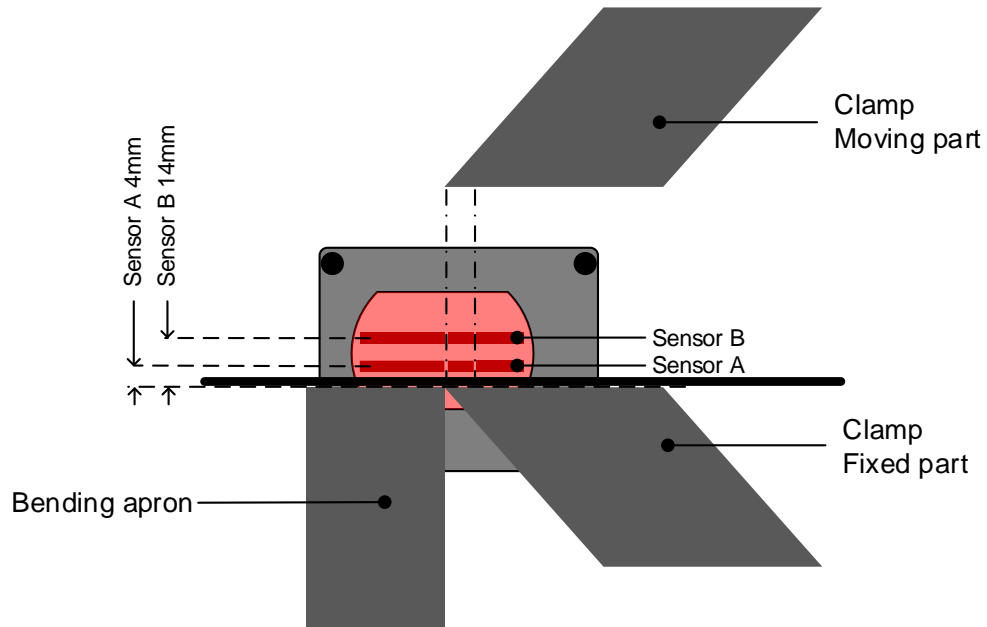

Figure 3-3: LZS-2-FG Sensor Detection Zones

Behind the front window of the LZS-2-FG receiver are two parallel laser sensors, sensor A and sensor B, that extend horizontally across the window. Each of these sensors is divided into three detection zones; the front, middle and rear. **Figure 3-3** shows the arrangement of the detection zones.

In the following illustrations the sensors are shown as red bars to indicate which sensors (A/B) and detection zones (front/middle/rear) are active, and which are muted. In reality, the sensors cannot be seen during normal operation, and the block laser appears as a flat red light on the receiver window. All diagrams are drawn as if viewing the **front** of the receiver.

**Figure 3-4** is a schematic representation of the optical guarding system seen from the transmitter (right hand) side of the machine, looking at the receiver. The laser transmitter/receiver pair are aligned to the fixed part of the clamp, such that the bottom sensor (sensor A) is 4mm above the fixed clamp. The top sensor (sensor B) is 10mm above sensor A.



**Figure 3-4: Sensor to Clamp (Fixed) / Mute Point Distance**

Stopping performance of the machine is also continuously monitored. If the machine fails to stop within safe limits, an emergency stop condition is triggered.

**3.3.1 Laser Classification and Warnings**



**Warning: CLASS 1 LASER DEVICE**

The LZS-2-FG block laser transmitter emits a CLASS 1 laser approximately 48 mm x 30 mm. Do not stare directly into the lasers or the transmitter window.

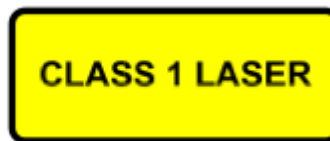

**Warning: CLASS 3R LASER RADIATION: DO NOT OPEN OR TAMPER WITH THE LASER TRANSMITTER**

The LZS-2-FG laser transmitter contains no user serviceable components. Do not attempt to tamper with, or dismantle the laser transmitter as this will void the product warranty and may expose you to the internal laser emitter CLASS 3R LASER RADIATION that has the potential to cause eye damage.

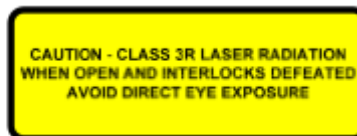

**3.3.2 Laser Transmitter and Receiver Setup**

The laser transmitter and receiver are installed on adjustable mounting brackets that are fixed to the floor on either end of the machine. The receiver is installed at the left hand side of the machine, and the transmitter is installed at the right hand side of the machine.



**Note:**

The LZS-2-FG sensors are divided into front, middle and rear detection zones. For the system to work correctly the receiver **must** be mounted on the left of the machine, and the transmitter on the right.

The mute point for each sensor is automatically set 2mm above the sensor. When the moving clamp closes, each sensor is muted independently when the opening between the clamp and the material is 16mm (for sensor B), and then 6mm (for sensor A).

**3.3.3 Mute Point**

FoldGuard must first establish the mute point, which is the point where the clamp enters the guarded area. When the clamp travels beyond this point the laser guarding is progressively deactivated in order to prevent the system considering the clamp as an obstruction which would trigger a stop of the machine.

After the initial start-up tests are completed FoldGuard automatically enters mute set-up mode and the operator is prompted to set the mute point. As the clamp moves down, the guarding system detects the point where sensor B is obstructed by the clamp. The operator is then prompted to either confirm this position as the correct mute point, or they may choose to repeat the set-up process. Once the mute point has been confirmed, the system automatically monitors the position of the clamp, and the mute point during operation.

**Figure 3-5** shows the beginning of the process; the clamp is open and both sensors are active.

When the clamp opening reaches 16mm sensor B is muted as shown in **Figure 3-6**.

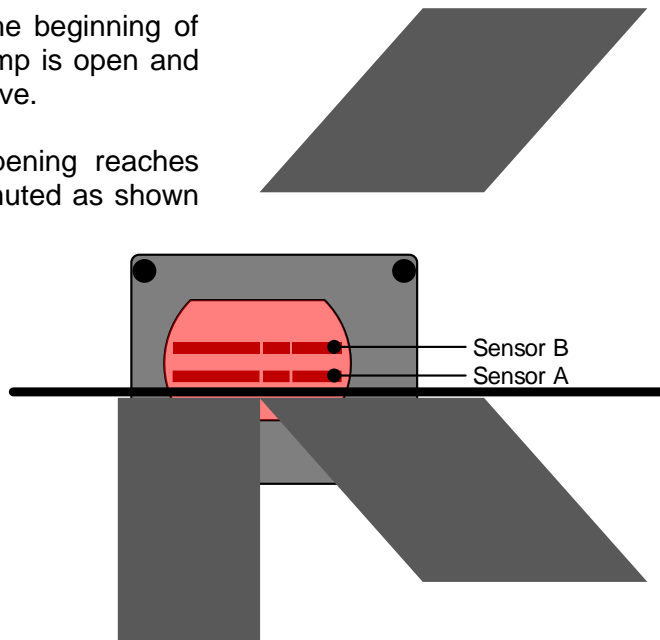

**Figure 3-5: The Muting Process – Clamp Opening >16mm**

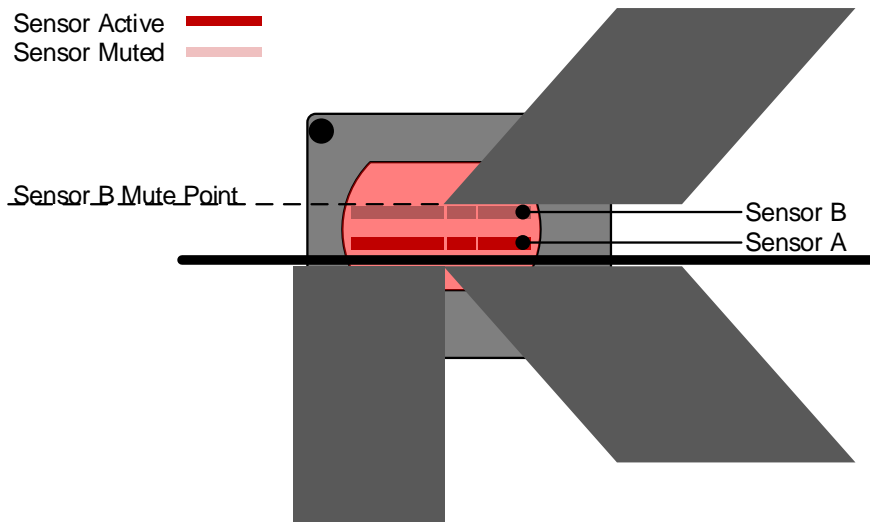

**Figure 3-6: The Muting Process – Clamp Opening = 16mm Sensor B Muted**



The clamp continues to move down and when the opening reaches 6mm, sensor A is also muted, as shown in **Figure 3-7**.

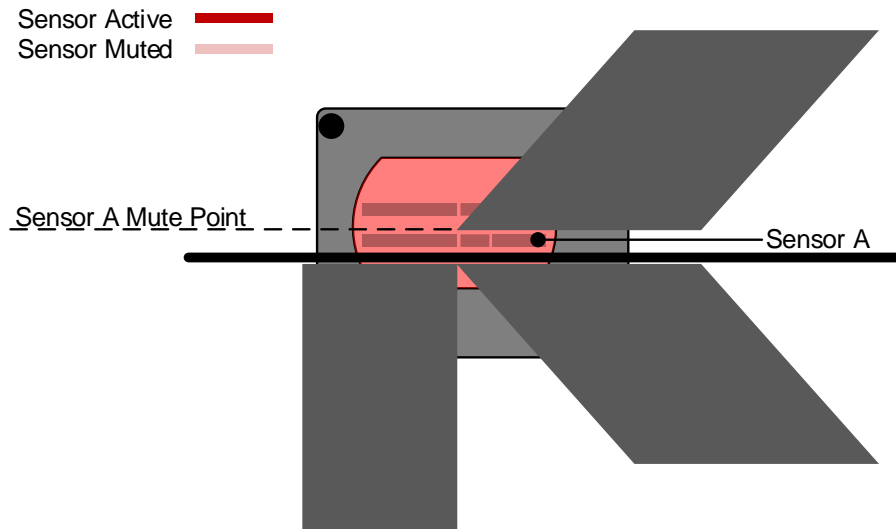

**Figure 3-7: The Muting Process - Clamp Opening  $\leq$  6mm Sensor A and Sensor B Muted**

## 3.4 Normal Mode

In Normal mode both sensors (A/B) and all zones (front/middle/rear) are active; this is the default mode at start-up. When the foot pedal is pressed the system checks if the sensors are clear and allows the clamp to close in high speed. The clamp speed is then reduced to slow speed (if the machine is capable of slow speed, refer **Section 2.2**) before the mute point (6mm) and clamps the material.



### Note:

The FoldGuard HMI displays the status of the machine, and any action that is required by the operator. In the following sections the operator messages are shown in the following format:

Status – ACTION

**Section 5** describes the operation of the FoldGuard User Interface Panel in detail.

### 3.4.1 Obstruction Detection – From a Stationary Position

If any sensor is obstructed when the pedal is pressed then the clamp will not move. The operator must release and press the pedal again. If the sensors are now clear, the clamp will start closing in high speed. If any sensor remains obstructed then the system will automatically mute the optical protection, and force the clamp to close in slow speed (if the machine is capable of slow speed, refer **Section 2.2**). The system then initiates a safety stop and the operator must release and press the pedal to clamp the material.

### 3.4.2 Obstruction Detection - When the Clamp is Closing

During high speed clamp closing all sensors are active. If any sensor is obstructed then the clamp is stopped. The operator must release and press the pedal to continue. If the sensors are clear then the clamp will start closing in high speed. If any sensor remains obstructed then the system will force the clamp to close in slow speed (if the machine is capable of slow speed, refer **Section 2.2**) but with the optical protection muted. The system then forces a safety stop and the operator must release and press the pedal to clamp the material.





### Warning: NO PROTECTION BELOW SAFETY STOP POSITION

Under certain circumstances the FoldGuard system will initiate a safety stop, and stop the clamp at the safety height (programmed in the System menu, refer [Section 7.3.4](#)).

**When the foot pedal is released and pressed again the clamp will close with the optical protection disabled. Particular caution must be exercised below the safety stop position.**

When all sensors are clear the clamp closes in high speed to the mute point, and then changes to slow speed (if the machine is capable of slow speed, refer [Section 2.2](#)) until the material is clamped.

## 3.5 Hemming Mode

Selecting Hemming mode changes the operation of the FoldGuard system, to provide the operator with the flexibility to perform hemming operations while the laser guarding is still active. The operator can select Hemming mode via the HMI.

### 3.5.1 First Stroke in Hemming Mode

When hemming mode is first selected both of the sensors (A/B) and all zones (front, middle and rear) are active, but they now function differently from Normal mode.

- The front sensor always operates as described in [Section 3.4](#), halting the machine when the laser guard is obstructed.
- The middle and rear sensors are used to detect and confirm the presence of the hemming material on the first pedal press only, and are disabled thereafter.

A hemming operation is shown in [Figure 3-8](#), where the material to be hemmed is allowed to obstruct the rear and middle sensor, but **not** the front sensor. The first pedal press is used to confirm that Hemming mode is indeed required, and the machine and operator are ready.

When the pedal is pressed for the first time after hemming mode is selected, the clamp will not move, and the Operator Panel will display the message Hem detected – RELEASE FOOT PEDAL. Hemming mode is now confirmed, and the middle and rear sensors are disabled (muted). The operation of the front sensor remains unchanged.

### 3.5.2 Operating in Hemming Mode

The next time the pedal is pressed, the clamp will close. As long as the front sensor remains unobstructed the clamp will move down at high speed, with the middle and rear sensors muted. The front sensor will continue to guard the danger zone at the front edge of the clamp.

Muting of the middle and rear sensors is controlled by a 30 second timer. If the machine remains idle (the foot pedal is not pressed), or if the machine is operated without any hemming obstructions for more than 30 seconds, the middle and rear sensors will be unmuted, and the Hemming mode confirmation will be reinitialised to operate as described in [Section 3.5.1](#) above.

#### Hemming Mode

In Hemming mode the middle and rear sensors are muted after the first pedal press. On the second pedal press the clamp can close at high speed to complete the hemming operation.

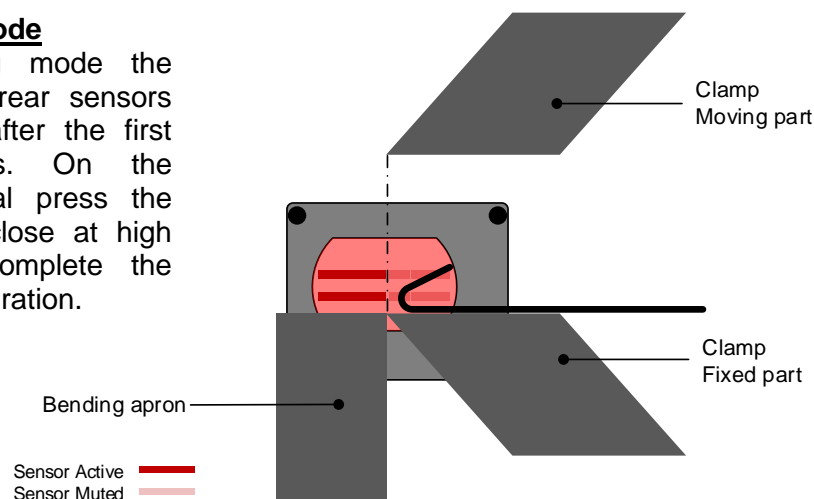

**Figure 3-8: Hemming Mode Operation - Middle/Rear Sensors Muted**

## 3.6 Field Muted Mode



### Warning: NO PROTECTION IN FIELD MUTED MODE

In Field Muted mode, the optical sensing is deactivated. Although FoldGuard engages the slow speed signal (if the machine is capable of slow speed, refer [Section 2.2](#)) and forces a safety stop on each cycle, particular caution must still be exercised.

**The ability to select Field Muted mode is disabled by default, and can only be enabled by personnel who have access to the Supervisor menu of the HMI. This menu is password protected and should only be accessible to suitably trained and qualified personnel.**

### Field Muted Mode

Block laser is OFF.  
Clamp can only close in slow speed.

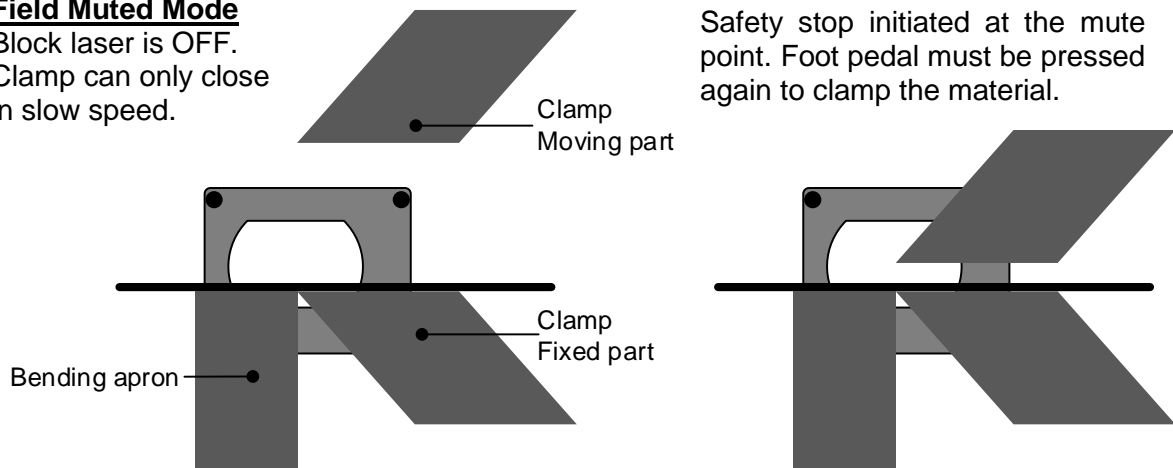

Figure 3-9: Field Muted Mode operation

In this mode, protection from the laser is muted (deactivated) for the entire stroke of the clamp and therefore does not provide optical protection. The FoldGuard system however maintains all its other safety functions and also forces a safety stop on each cycle.

Field Muted mode should only be used in cases where it is not possible to use any other mode with active protection.

## 3.7 Safety Stop Mode

The Safety Stop mode automatically forces the clamp to stop at a pre-defined distance above the material. The operator must release and press the foot pedal again to complete the clamping operation in slow speed (refer to [Section 2.2](#)).



### Warning: NO PROTECTION BELOW SAFETY STOP POSITION

Under certain circumstances the FoldGuard system will initiate a safety stop, and stop the clamp at the safety height (programmed in the System menu, refer [Section 7.3.4](#)).

**When the foot pedal is released and pressed again the clamp will close with the optical protection disabled. Particular caution must be exercised below the safety stop position.**

## 3.8 Bending Apron Mode

In some folding machines the clamp and bending apron share a single hydraulic system. If this hydraulic system is restricted in order to force slow speed (for example when the clamp is below the mute point) then the bending apron may not operate correctly.

In this case, the FoldGuard system provides inputs for four Bending Apron Enable signals. Activating any of these inputs will disable the slow speed output, and allow the bending apron to operate at full speed.

**Warning: HIGH SPEED BENDING APRON MOVEMENT**

The Bending Apron Enable signal should be linked to the machine controller, to ensure that by this stage of the folding process the material is clamped. Always exercise caution when any part of the machine is operating in high speed.

### 3.9 Emergency Stop Inputs

The FoldGuard system supports four operator controlled emergency stop switch inputs:

- E-Stop Pushbutton.
- Kick Bar.
- Pedal 1.
- Pedal 2.

These are all normally closed, dual contact safety switch inputs. If an emergency stop condition is triggered by the operator the machine will be immediately stopped, and the source of the emergency stop identified by a message on the User Interface Panel. The emergency stop must then be cleared before normal operation can continue.

If more than one emergency stop input is active at the same time a general emergency stop message will be displayed. All emergency stop controls must then be checked in turn by the operator until the source is determined, and cleared.

If any of the safety inputs is in a state that is not valid for a dual contact safety switch, the operator will be informed that a switch is faulty. All emergency stop inputs must then be tested, and if necessary repaired before the machine can re-enter service.

### 3.10 No Guard / No Counter Mode

The OEM version of FoldGuard provides the manufacturer with the option of installing the system without the LZS-2-FG laser guards, optical encoder or User Interface Panel. In this case the FoldGuard system acts as a safety controller monitoring the emergency stop inputs only, with the option of being upgraded to a complete FoldGuard system at a later date.

### 3.11 Closed Loop Design

As well as the optical protection provided by FoldGuard, the system also monitors the movement of the machine.

This closed loop design enables monitoring of the stopping distance (overrun) of the pressing beam every time it stops. If the stopping distance limit is exceeded, an emergency stop condition is triggered, and the machine is shut down.

The system also monitors the machine process for failures of hydraulic valves, failures of electrical components, and failures in the machine controller software in relation to the actions of the parts of the machine that pose risk to the operator.

## 4 Transmitter and Receiver Alignment

Before operating the machine it is necessary to check the alignment of the laser transmitter and receiver. While the alignment should never require adjustment after the system has been installed, it is necessary for this alignment to be periodically checked to ensure correct and safe operation. The alignment should be checked each day before operating the machine and at the start of each shift or operator change.



### Warning:

The machine should not be operated until the alignment of the FoldGuard transmitter and receiver is verified.

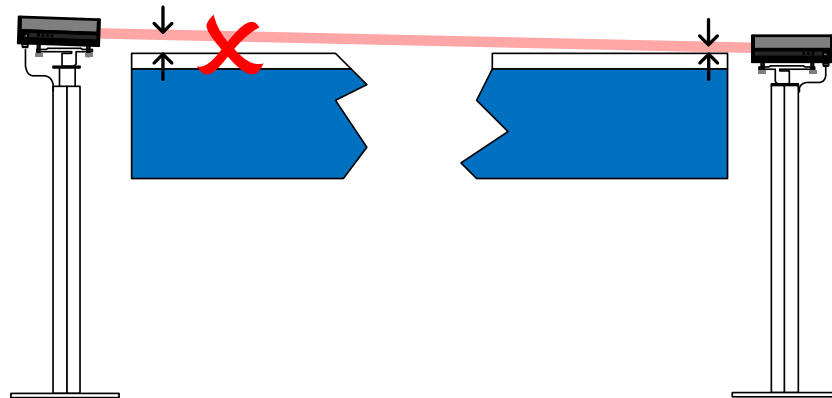

**Figure 4-1: Laser Guard Misaligned – Not Parallel to Clamp**

The importance of correct alignment can be seen in **Figure 4-1**. Although laser guarding is active and will operate correctly, due to misalignment between the laser guard and the bed of the folding machine there is a large unguarded gap at the left of the machine. This is unsafe, as a finger or hand could be placed in this gap without triggering an obstruction.

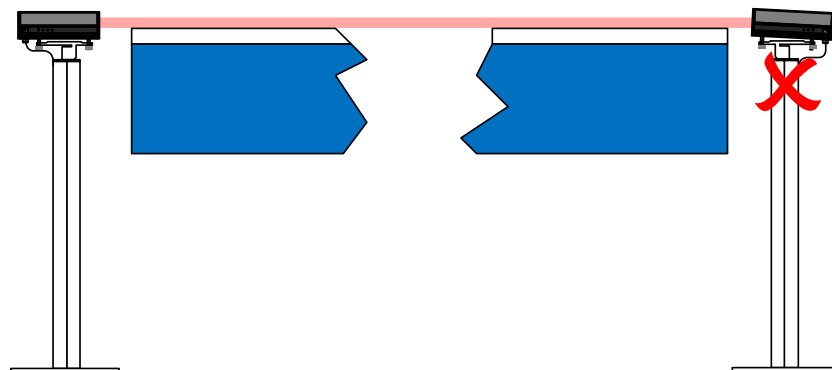

**Figure 4-2: Laser Guard Misaligned - Receiver Not Level**

**Figure 4-2** is an example of how the receiver can be misaligned. Although the laser is parallel to the folding machine bed, the receiver is not level and square to the laser. Sensor B is aligned correctly, however as sensor A and sensor B are separated by a distance of 10mm, sensor A may not detect the clamp reliably. This could lead to intermittent problems during operation of the machine, particularly when the clamp approaches the mute point, resulting in reduced productivity.

Lazer Safe provides an alignment tool to ensure that the LZS-2-FG is aligned accurately to the folding machine bed and clamp. Refer to the ***Lazer Safe Folding Machine Alignment Guide (LS-CS-M-051)*** for instruction on how to perform the alignment.

# 5 The FoldGuard User Interface Panel

## 5.1 User Interface Overview

The User Interface Panel is an advanced, industrial grade Human Machine Interface (HMI) specifically designed for the FoldGuard system. The operator controls the FoldGuard Folding Machine Guarding System through a simple, menu-style user interface. The key features of the interface panel are shown in **Figure 5-1**.

**Status Window**

This window shows the current status of the folding machine, and of the FoldGuard system.

**Action Window**

The FoldGuard system displays what action is required by the operator in the Action Window.

**Operator Pushbuttons**

Five pushbuttons are provided for the operator to control the FoldGuard system and navigate the menus.

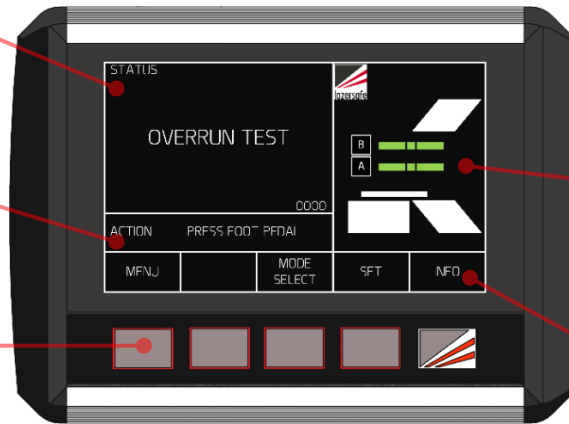

**Magnetic Backing**

The panel can be mounted and moved for the convenience of the operator.

**Sensor window**

This window shows the status of the receiver sensors, and the active mode.

**Dynamic Button Labels**

The button functions change depending upon the selected screen and machine state.

**Figure 5-1: FoldGuard User Interface Panel**

**Figure 5-2** shows the different FoldGuard User Interface Panel screens that can be selected by the operator. The Main screen is the top level screen (the screen also shown in **Figure 5-1**). From here the operator can select the other FoldGuard screens using the panel pushbuttons.

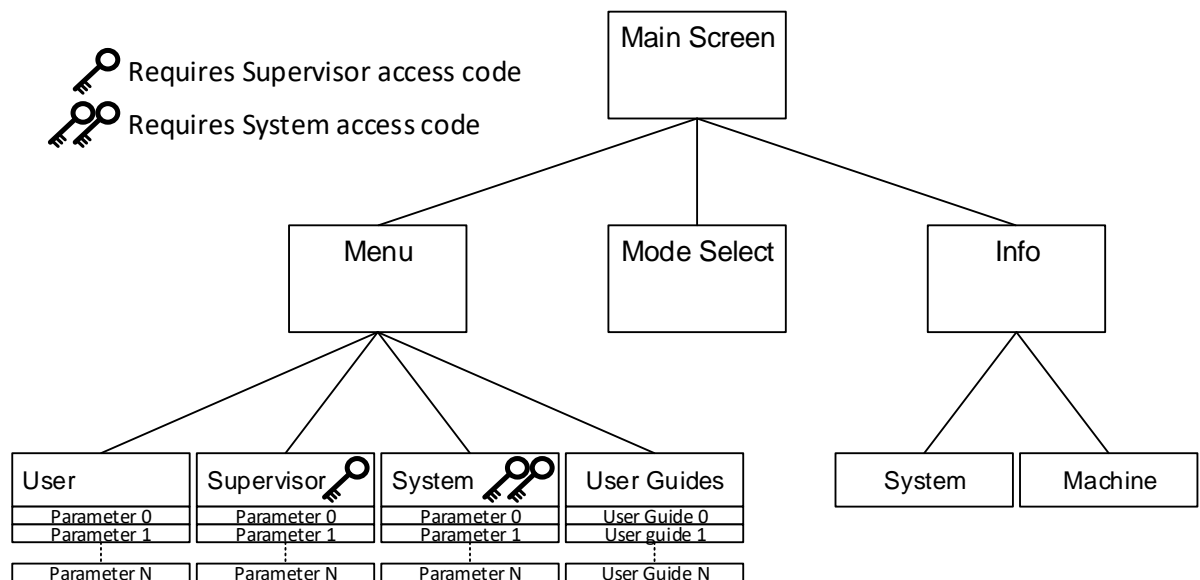

**Figure 5-2: FoldGuard Menu Levels**



**Note:**

An operator only needs to be familiar with the Main and Mode Select screens to perform most typical machine operations. The Mode Select screen is only required when changing guard modes.

There are three levels of access to the menu system; User, Supervisor and System. The Supervisor and System menus are restricted, and each requires a unique four-digit code to be entered before they can be accessed. This document only describes the User and Supervisor menus.

## 5.2 Error Reset Indicator and Reset Button

Aside from the User Interface Panel the FoldGuard system requires an external error reset lamp to indicate that an error or fault condition has occurred, and an error reset switch that is pressed to clear the error. These are typically combined into an illuminated pushbutton that is mounted on the side of the folding machine.

The reset indicator can be in one of three states:

- **OFF.** System status is normal – no error, no action is required.
- **ON.** An error has occurred – press the reset button once.
- **ON/FLASHING.** Multiple errors have occurred, press the reset button twice.

If the error cannot be cleared by pressing the reset button multiple times, then a fault or emergency stop condition has occurred that must be corrected before the error can be cleared. See the Status and Action screens of the FoldGuard User Interface for further information.

If the error cannot be cleared contact your supplier or Lazer Safe Customer Support for assistance [customerservice@lazersafe.com](mailto:customerservice@lazersafe.com).

## 5.3 Mute Indicator

The Operator can clearly see when the FoldGuard system's optical protection is muted, as the background of the Status screen on the User Interface Panel turns RED.

## 5.4 The Main Screen

The Main screen is the top level screen of the FoldGuard User Interface Panel, and is shown in **Figure 5-3**. The screen is divided into four windows; The Status, Action, Button Labels and Sensor windows.

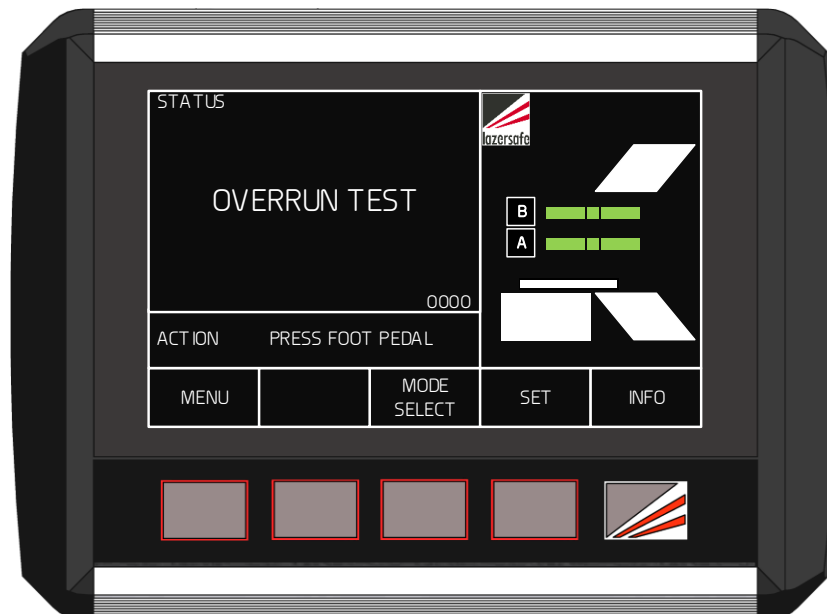

**Figure 5-3: The FoldGuard Main Screen**



**Note:**

If the FoldGuard system is idle (no button or foot pedal press) for more than 5 minutes it will display an idle screen. A button or foot pedal press will return the panel to the most recently displayed screen.

### 5.4.1 Status and Action Windows

The Status window informs the operator of the current status of the FoldGuard system, and the machine it is guarding. The information provided by the Status screen includes:

- **Operating Mode.** The guard mode currently selected (Normal, Hemming or Field Muted) is displayed during operation. This message will be overwritten if an error/fault condition occurs.
- **Mute Status.** The Status window turns red whenever the guarding is muted, to clearly indicate to the operator that guarding is inactive.
- **Error/Fault Messages.** If the FoldGuard system detects an error or fault condition the operator will be alerted by the Status window. In most cases this will be a short message that describes the error/fault condition.
- **Condition Code.** The Safety Controller displays condition codes on its scrolling LCD panel to communicate actions, errors or faults. These codes are displayed as a 4-digit hexadecimal code (numbers 1-9, letters A-F) that uniquely describes a particular condition or machine state. This condition code is also displayed in the lower right hand corner of the Status window.
- **Operation Pending:** If the Safety Controller requires that an operation is to be performed to verify the safety performance of the machine (such as an overrun test) the operator is informed of the upcoming operation in the Status window (and is also prompted for an action by Action window message).

The Action window prompts the operator with the action required to complete the current operation. For example, if a fault condition occurs, the error message and condition code are displayed in the Status window, while the Action window prompts the operator to PRESS RESET.

### 5.4.2 Main Screen Button Labels

The five buttons on the User Interface Panel change function depending upon the current screen, the Supervisor menu configuration, and the state of the machine. The button labels for the Main screen are shown in **Table 5-1**.

Label	Button Function
MENU	This leaves the Main screen and enters the Menu screen. See <b>Figure 5-2</b> for an overview of the menu system.
NOT USED	This button is not active in the FoldGuard system.
MODE SELECT	Leaves the Main screen and enters the Mode Select screen, where the guard modes can be selected.
SET/MUTE RESET	This button can be used to set or reset the mute point. The button label changes depending upon the state of the mute point.
INFO	This leaves the main screen and enters the Info Screen. See <b>Figure 5-2</b> for an overview of the menu system.

**Table 5-1: Main Screen Buttons**

### 5.4.3 Sensor Window

The Sensor window shows the status of the optical protection from the point of view of the receiver. Symbols in the window show the current active mode, and the state of the receiver sensors (A/B) in real time. The general appearance of the window (with laser optical protection active) is shown in **Figure 5-4**, although this will change depending upon the protection options selected.

In the following sections the Sensor window will always be shown with the appropriate symbols for the operating mode being described.



**Material**

This symbol shows that the guarding is set to Normal mode. This symbol will change when Hemming mode is selected.

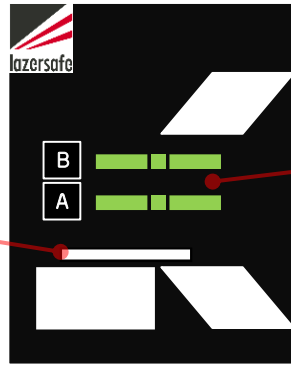

**Sensor A, B**

When the optical guarding is active these symbols show the status of the **FRONT, MIDDLE** and **REAR** sensors of the laser receiver – green for clear, red for obstructed.

**Figure 5-4: Sensor Window**

**5.5 Mode Select Screen**

The other screen used in most typical machine operations is the Mode Select screen. This only differs from the Main screen in the function of the five input buttons.



**Figure 5-5: Mode Select Screen**

The buttons are used to select the different guard modes (the modes are detailed in **Sections 3.4 to 3.9**). The operation of the Mode Select screen and the Sensor window symbols is explained in **Section 6**.

Label	Button Function
	This leaves the Menu screen and returns to the Main screen. See <b>Figure 5-2</b> for an overview of the menu system.
GUARD MODE	This button cycles through the guard modes: Normal → Hemming → Normal etc.
FIELD MUTED	If this button is enabled, it toggles the Field Muted mode. The functionality of this button is disabled by default, and can be configured in the Supervisor menu.
SAFETY STOP	If this button is enabled, it toggles the Safety Stop mode. The functionality of this button can be configured in the Supervisor menu.
NOT USED	This button is not used in the Mode Select screen.

**Table 5-2: Mode Select Screen Buttons**



## 5.6 Menu Screen

The Menu screen gives access to the menus that are used to configure the way that the FoldGuard system operates. There are three levels of access to the menu system; User, Supervisor and System. The User and Supervisor menus are detailed in **Section 7**.

The User level menu does not require an access code, and can be accessed by anyone operating the machine.

The Supervisor level menu requires an access code. This menu contains parameters that configure how the FoldGuard system and the User Interface Panel operate. This menu should only be accessible to suitably trained and authorized personnel.

The System menu requires an access code. (This is the highest level access code, and can also be used to access the Supervisor level menu). This menu contains machine/site specific parameters that are set during the installation of the FoldGuard Folding machine Guarding System. The System menu is **not** described in this document.



**Warning:**

**The System menu does not contain any user configurable parameters. System menu parameters must only be configured by trained and qualified FoldGuard installers. Setting incorrect parameter values may render your machine inoperable.**

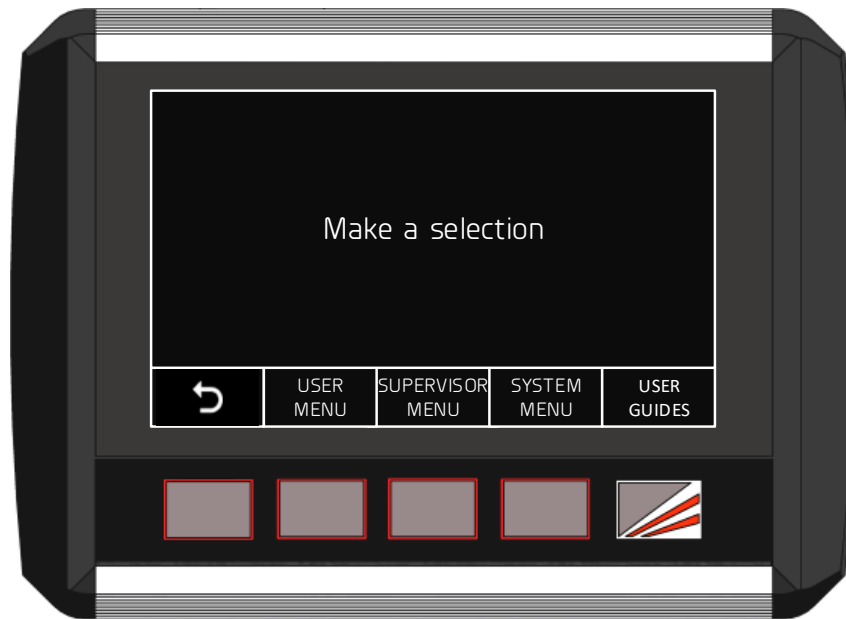

**Figure 5-6: Menu Screen**

Label	Button Function
	This leaves the Mode Select screen and returns to the Main screen. See <b>Figure 5-2</b> for an overview of the menu system.
USER MENU	This accesses the User menu. No access code is required.
SUPERVISOR MENU	This accesses the Supervisor menu. An access level of Supervisor or System level is required.
SYSTEM MENU	This accesses the System menu. An access level of System is required.
USER GUIDES	This accesses instructional guides on the operation of the FoldGuard system. No access code is required.

**Table 5-3: Menu Screen Buttons**

Once a menu has been selected the parameters can be navigated, selected and edited. The parameters are stored in non-volatile memory that is maintained even when the FoldGuard system is powered down. Refer to **Section 7** for detailed instructions on how to navigate and configure the User and Supervisor menus.



**Note:**

When any menu screen is selected, the safety application running on the Safety Controller turns off the enable outputs, and the machine cannot run. If the foot pedal is pressed, the Safety Controller’s LCD display will show the Condition Code **40A1**.

**5.6.1 User Guides**

The User Guides are navigated in the same way as menus, using the arrow buttons. The arrow buttons step through the list of guides; the desired guide is then selected by pressing the ENTER button. Refer to **Section 7.1.1** for a description of how to navigate menus.

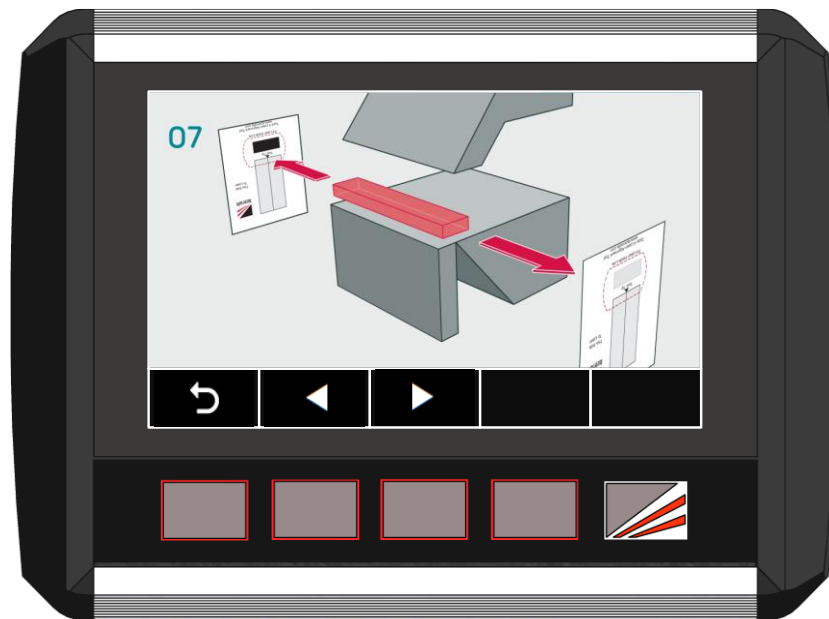

**Figure 5-7: User Guide Screen**

Label	Button Function
	This leaves the User Guide and returns to the User Guide list. See <b>Figure 5-2</b> for an overview of the menu system.
	Selects the next page in the guide.
	Selects the previous page in the guide.

**Table 5-4: User Guide Buttons**

The User Guides are simple, step by step graphical guides for common procedures that need to be performed regularly on Lazer Safe equipment (such as how to align LZS-2-FG laser guards). If the guide contains more than one page, the left/right arrow keys can be used to navigate the pages of the guide.

**5.7 Info Screen**

The Info screen is selected from the Main screen, and displays information about the FoldGuard system, and the folding machine. The screen can be switched between displaying System Information and Machine Information.

**Note:**

The system parameters are stored in the FoldGuard User Interface, and the system cannot run if the panel is disconnected.

The safety application running on the Safety Controller monitors a system heartbeat signal from the HMI. If the heartbeat signal is not detected for 10 seconds, the safety application disables the down enable outputs. If the foot pedal is pressed, the Safety Controller's LCD screen shows the Condition Code **40A1**.

**This does not apply to systems configured for No Guard / No Counter.**

### 5.7.1 System Information

System Information is displayed by pressing the **SYSTEM INFO** menu button in the Info screen.

- **Comm Status.** A heartbeat message is transmitted constantly between the Safety Controller and the panel to verify the integrity of the communications link. The Comm status field shows the state of the communications link; **Connected** or **Not connected**.
- **HMI type.** The User Interface Panel or HMI is used in several Lazer Safe guarding products. This is the particular guarding system for which the panel has been configured.
- **HMI version.** The FoldGuard User Interface Panel software version.
- **Kernel version.** The Safety Controller kernel software version.
- **Application.** The Safety Controller application software version.
- **FPGA version.** PGS-2 Safety Controller FPGA firmware version.
- **Approx. slow point.** The slow speed point calculated by the FoldGuard. The press brake must be travelling in slow speed by this opening (in millimetres).
- **Laser-punch.** This is not used in the FoldGuard system, and should always be 14mm.

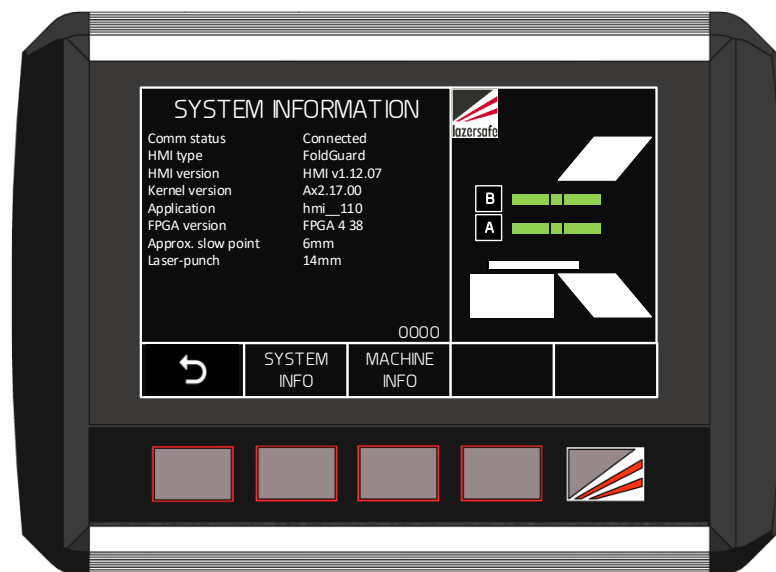

**Table 5-5: Info Screen, System Information**

When contacting Lazer Safe Customer Support or your local dealer, please provide the system software version information from the System Info menu.

### 5.7.2 Machine Information

Machine Information is displayed by pressing the **MACHINE INFO** menu button in the Info screen.

- **Stop Time.** Measured by the Safety Controller each time the beam is stopped.
- **Stop Distance.** Measured by the Safety Controller each time the beam is stopped.
- **Stop Time Limit.** This parameter does not apply to the FoldGuard system.

## 6 System Operation

This section describes the operation of the FoldGuard Folding Machine Guarding System from power up.

### 6.1 Power-up

When the FoldGuard is first powered it displays a start-up screen with the message **SYSTEM STARTING – PLEASE WAIT**, while it waits for the Safety Controller to complete its power on start-up test. Once the Safety Controller is initialised, the screen will change to the standard Idle screen as shown in **Figure 6-1**. Whenever the machine is idle for more than five minutes, it will return to the Idle screen.

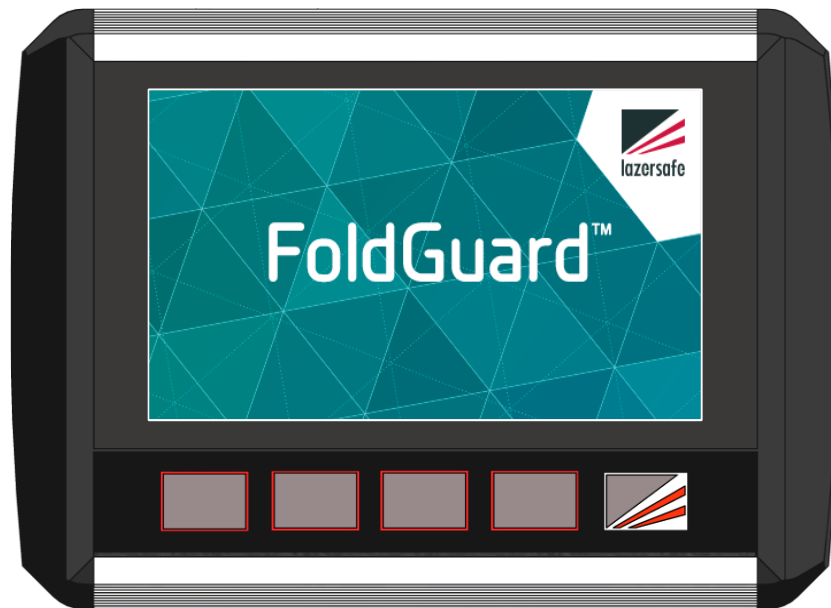

Figure 6-1: FoldGuard Idle Screen

### 6.2 Start-up Test

When first started, FoldGuard must perform an overrun test to test the function of the Safety Controller emergency stop outputs, and the stopping performance of the folding machine. The operator is warned of the upcoming test by the message in the Status screen, see **Figure 6-2**.

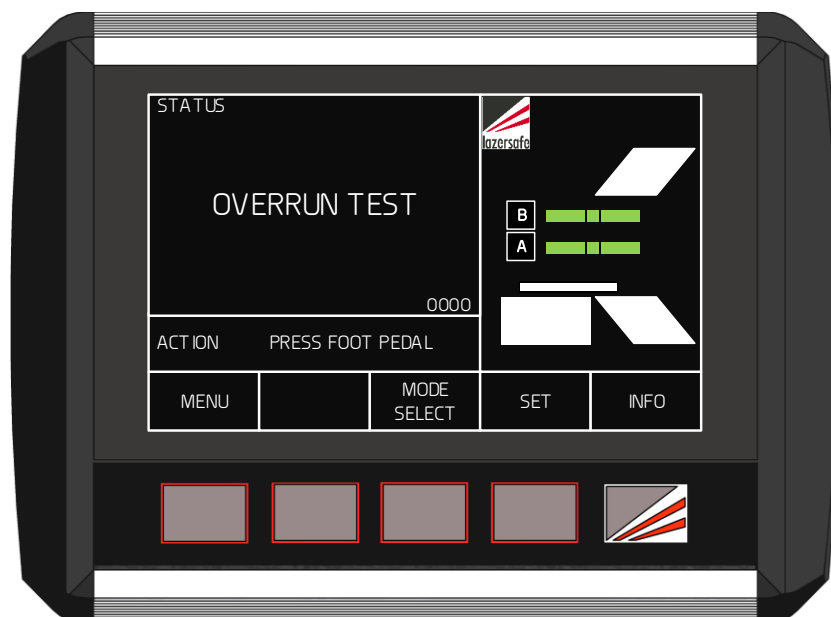

Figure 6-2: Start-up Test Screen

Immediately after power up the emergency stop outputs are in the OFF state. Press the Reset button to turn on the E-Stop and Enable outputs.

Before performing the overrun test check the following.

- Open the clamp to a minimum opening of 100mm.
- Check that the transmitter and receiver are correctly aligned.
- Check the clamp (fixed part) to laser distance.
- Check that the receiver sensors are clear (see the LZS-2-FG receiver, the Safety Controller front panel, or the Sensor window of the FoldGuard User Interface Panel).

To commence the test, press the foot pedal as indicated in the Action window. The first foot pedal press performs a test on the laser guards, and alerts the operator that the system is changing to Normal mode, as shown in **Figure 6-3**.

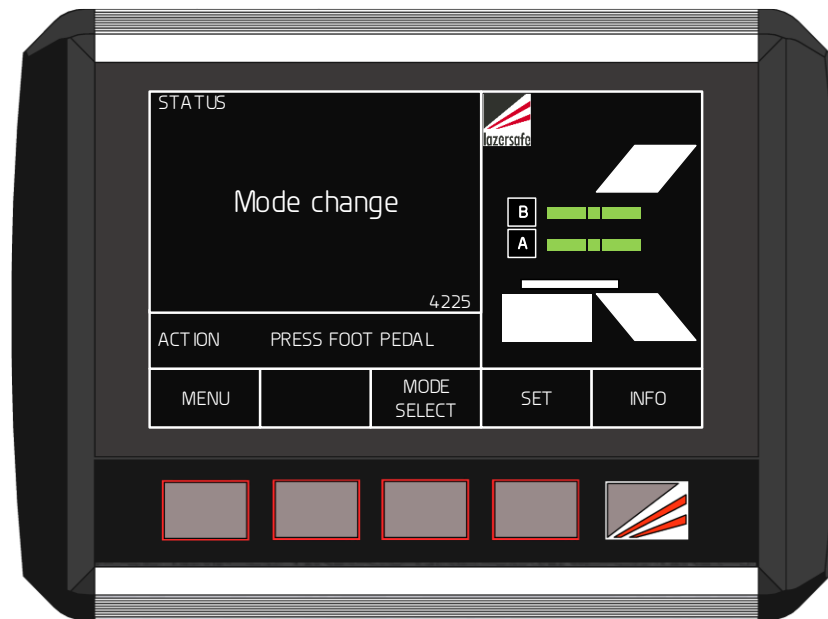

**Figure 6-3: Mode Change Status Message**

Release and press the foot pedal again. The clamp will start closing in high speed, and then automatically stop after a short distance. When the test is complete the operator will be prompted to release the pedal: **Overrun test PASS – RELEASE FOOT PEDAL**.



**Note:**

After the start-up test is complete it may be necessary to reset the machine emergency stop circuit and/or restart the hydraulic pump.

The overrun test is performed at start-up, every 24 hours (if the machine is not power cycled) or if the stopping distance monitoring indicates that stopping performance has deteriorated significantly during normal operation.

### 6.3 Setting the Mute Point

After the start-up test is complete, the operator will be prompted to set the mute point by the message **SET MUTE POINT – PRESS FOOT PEDAL**. The FoldGuard panel must be in the Main screen to access the SET button.

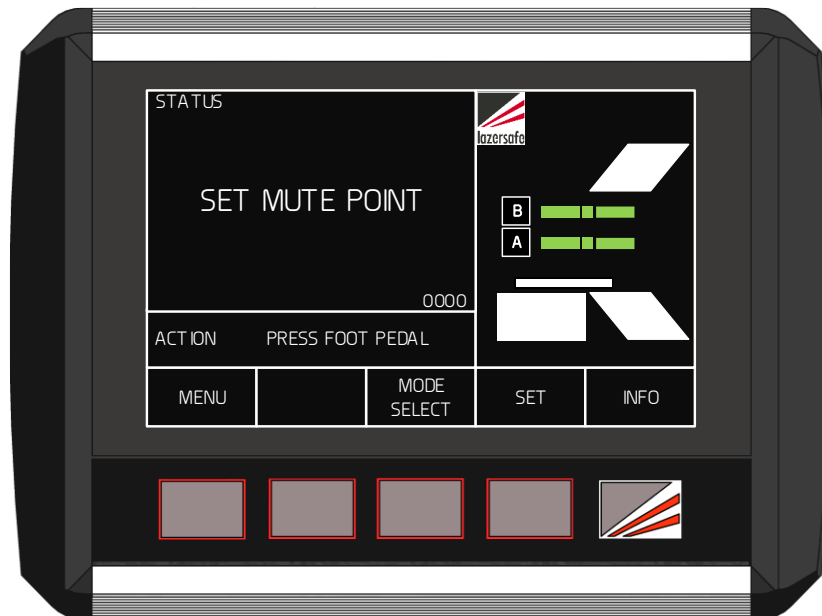

**Figure 6-4: Set Mute Point Prompt Screen**

Press the foot pedal. The clamp will close until sensor B (the top sensor) is obstructed by the clamp. The Sensor window will show sensor B as obstructed, and the SET button will change colour to green, which indicates that the mute point can now be set, see **Figure 6-5**.



**Note:**

During mute point set-up the FoldGuard guarding system uses only the rear and middle zones of the receiver to detect the clamp.

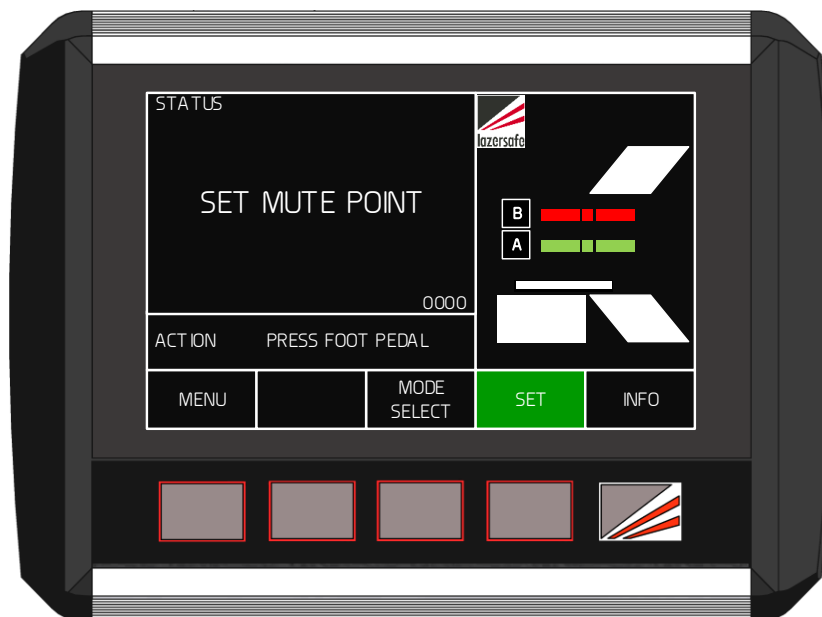

**Figure 6-5: Sensor B Obstructed by the Clamp**

Release the foot pedal. The Status screen changes to a red background, and prompts the operator to **CONFIRM MUTE POINT - PRESS SET BUTTON**, as shown in **Figure 6-6**. If this position is not correct, open the clamp and repeat the process.

To confirm the detected position as the mute point, press the SET button. The Status screen will change back to black, and the SET button label changes to **MUTE RESET** as shown in **Figure 6-7**.

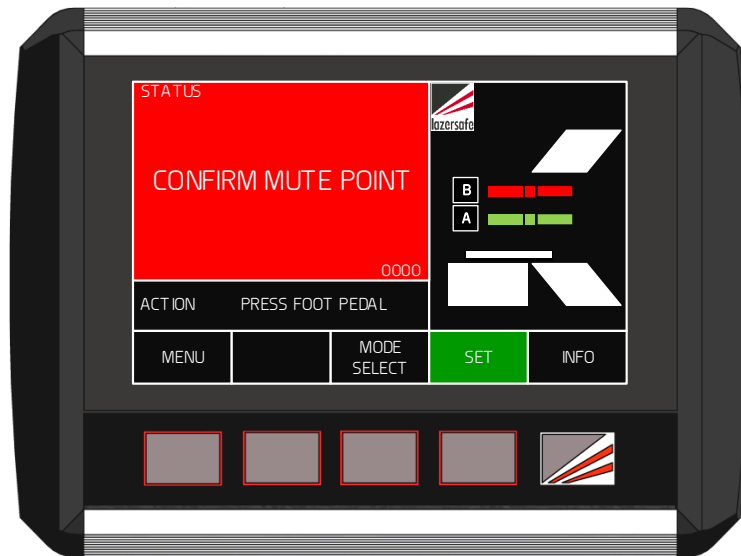

**Figure 6-6: Confirm Mute Point Screen**

The Status screen now displays the message **NORMAL MODE Ready to bend**.



**Note:**

If FoldGuard detects that the clamp has closed three times but no attempt has been made to set a mute point (the sensors have not been obstructed), a safety stop will be forced. This will continue until the sensors have been obstructed and the mute point set.

After the mute point has been set, the system enforces an overtravel limit on the clamp travel to ensure that the optical protection has been set at the correct height above the lower clamp. If the clamp travels more than the overtravel limit below the clamping point (set by the mute point) the clamp is stopped and must be retracted manually.

The overtravel limit is set between 6mm and 12mm when the system is installed.

## 6.4 Resetting the Mute Point

If for any reason the mute point needs to be reset, open the clamp fully and press the **MUTE RESET** button. If the machine is not fully open, the message **Open clamp to enable** button function will be displayed in the Status window.

When pressed and released, the **MUTE RESET** button will flash three times while the mute point is cleared, and the screen again appears as in **Figure 6-4** prompting the operator to **SET MUTE POINT – PRESS FOOT PEDAL**.

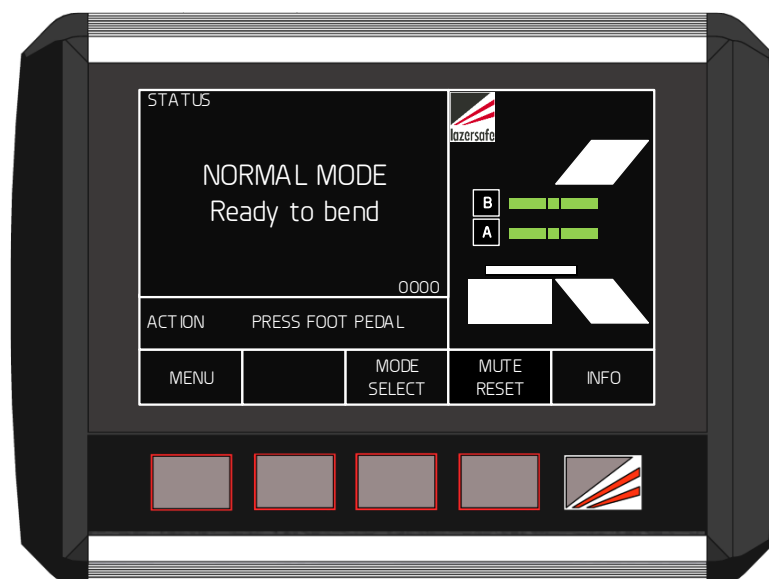

**Figure 6-7: Mute Set, Ready to Bend**

**Note:**

Do not press the foot pedal while the MUTE RESET label is flashing. If the foot pedal is pressed, the mute reset operation will be cancelled.

## 6.5 Selecting Hemming Mode

To change the optical protection mode, the FoldGuard User Interface Panel must be in the Mode Select screen. From the Main screen press the **MODE SELECT** button, and the screen will change to the Mode Select screen.

When changing modes the clamp must be open above the mute point, and the laser protection must be clear of any obstructions. The system should be in Normal mode (the default start-up mode). If these conditions are not met, the Status window will display the message **Open clamp to enable button function**.

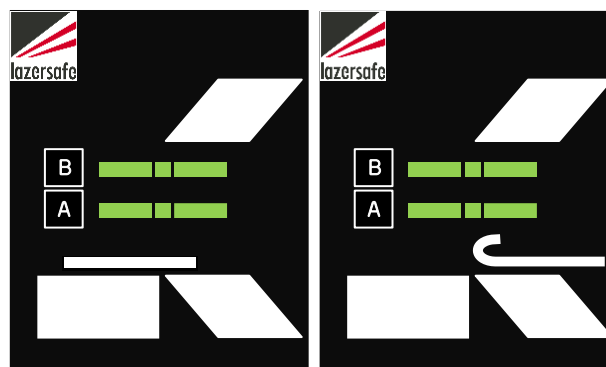

**Figure 6-8: Mode Select Screen**

- Press the **GUARD MODE** button to enter Hemming Mode.
- Press the **GUARD MODE** button again to return to Normal mode.

The selected mode is displayed as a message in the Status screen (as long as no error messages are current), and as a symbol in the Sensor window.

**Figure 6-9** shows the Sensor window for Normal and Hemming modes. When Hemming mode is selected, the system will operate as described in **Section 3.5**.



**Figure 6-9: Sensor window, Normal (left), and Hemming Mode (right) Symbols**



The mute point is stored in system memory and does not need to be set again when changing between Normal and Hemming mode. If the operator needs to reset the mute point while in Hemming mode, the procedure is the same as described in [Section 6.4](#), except that when the material is detected, the message Front/rear sensor blocked is displayed until the foot pedal is released.

## 6.6 Selecting Field Muted Mode

To change the optical protection mode, the FoldGuard User Interface Panel must be in the Mode Select screen. From the Main screen press the **MODE SELECT** button, and the screen will change to the Mode Select screen.

When changing modes the clamp must be open above the mute point, and the laser protection must be clear of any obstructions. The system should be in Normal mode (the default start-up mode). If these conditions are not met, the Status window will display the message Open clamp to enable button function.



Figure 6-10: Mode Select Screen - Field Muted Mode



### Warning: NO OPTICAL PROTECTION IN FIELD MUTED MODE

In Field Muted mode, the optical sensing is deactivated. Although FoldGuard engages the slow speed signal (if the machine is capable of slow speed, refer [Section 2.2](#)) and forces a safety stop on each cycle, particular caution must still be exercised.

**The ability to select Field Muted mode is disabled by default, and can only be enabled by personnel who have access to the Supervisor menu of the HMI. This menu is password protected and should only be accessible to suitably trained and qualified personnel.**

To enter Field Muted mode press the **FIELD MUTED** button. When the FoldGuard system enters Field Muted Mode the screen will appear as shown in [Figure 6-12](#). The **FIELD MUTED** button turns green, the Status screen turns red (to indicate that the optical protection is muted), and the message **FIELD MUTED MODE – Ready to bend** is displayed. The Sensor window now indicates that there is no optical protection (no sensor state is displayed).



### Note:

The Field Muted button functionality can be enabled through a parameter in the Supervisor menu. [Figure 6-11](#) shows the state of the button for the menu options (left to right) Enabled, Disabled-ON and Disabled-OFF.



**Figure 6-11: Field Muted Button Options (left to right) Enabled, Disabled-ON, Disabled-OFF**

The system now behaves as described in **Section 3.6**. When the operator presses the pedal for the first time the clamp will **not** close and the message **Mode Change – RELEASE FOOT PEDAL** is displayed in the Status window. This alerts the operator that the optical protection mode has changed. As a safety stop will be enforced every time the clamp is closed, the safety stop symbol is also displayed in the Sensor window.

When the pedal is released and again pressed, the clamp will close with the speed restricted to slow speed (if the machine is capable of slow speed, refer **Section 2.2**), and the message **LASERS INACTIVE** is displayed in the red Status window, as shown in **Figure 6-12**. A safety stop is forced before the clamp closes.

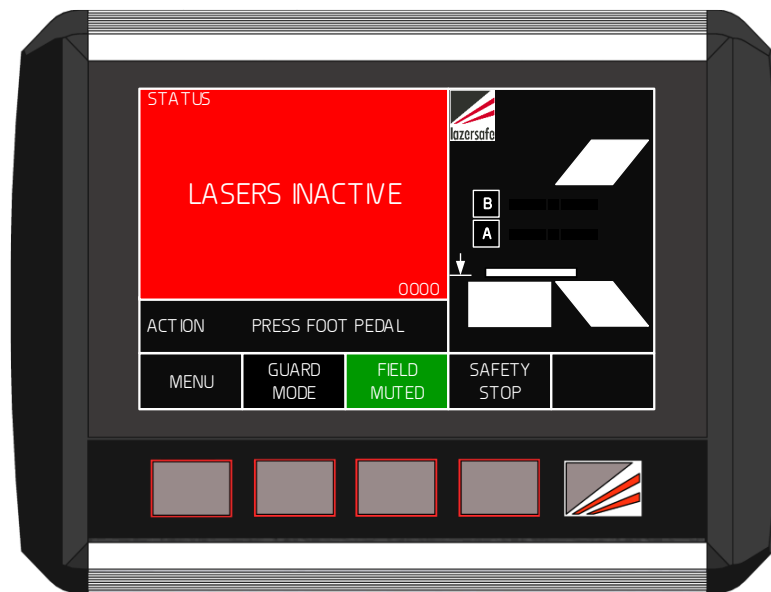

**Figure 6-12: Closing Clamp in Field Muted Mode**

### 6.6.1 Exiting Field Muted Mode

To exit Field Muted mode and return to Normal mode press the **GUARD MODE** button when the clamp is open. If the clamp is not open, the Status window will display the message **Open clamp to enable button function**.

The FoldGuard system will always return to Normal mode after Field Muted mode, and will again appear as in **Figure 6-8**. When the foot pedal is pressed for the first time after returning to Normal mode the clamp will not close, and the message **Mode Change – RELEASE FOOT PEDAL** is displayed to inform the operator that the FoldGuard system has changed mode.

## 6.7 Selecting Safety Stop Mode

To select Safety Stop mode the FoldGuard User Interface Panel must be in the Mode Select screen. From the Main screen press the **MODE SELECT** button, and the screen will change to the Mode Select screen.



### **Warning: NO PROTECTION BELOW SAFETY STOP POSITION**

Under certain circumstances the FoldGuard system will initiate a safety stop, and stop the clamp at the safety height (programmed in the System menu, refer **Section 7.3.4**).

**When the foot pedal is released and pressed again the clamp will close with the optical protection disabled. Particular caution must be exercised below the safety stop position.**

When changing modes the clamp must be open above the mute point, and the laser protection must be clear of any obstructions. If these conditions are not met, the Status window will display the message Open clamp to enable button function.

Safety Stop mode is used in conjunction with other guarding modes. For example, a Safety Stop can be selected in Normal or Hemming mode, and is automatically forced when Field Muted mode is selected. To enable Safety Stop mode press the SAFETY STOP button. The SAFETY STOP label will turn green, and the Sensor window now displays the Safety Stop symbol, as shown in **Figure 6-13**. The FoldGuard system now behaves as described in **Section 3.7**.

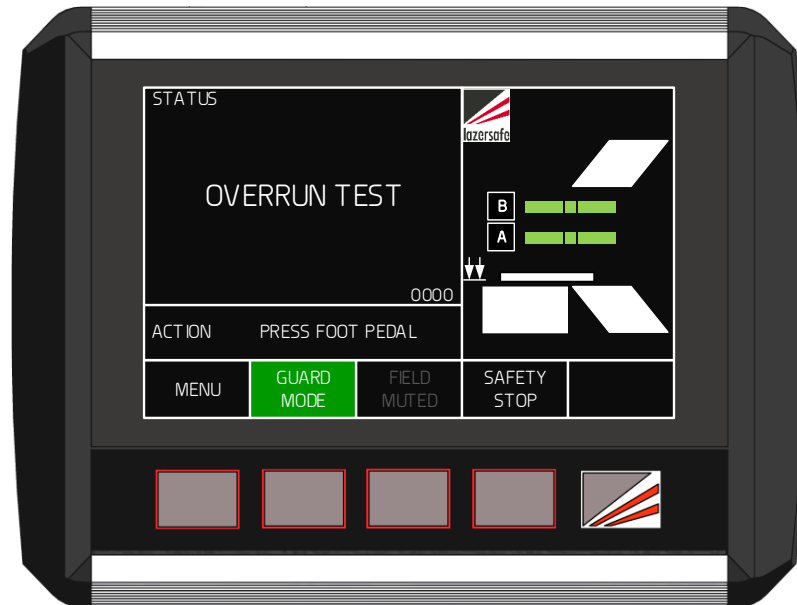

**Figure 6-13: Normal Mode + Safety Stop Mode**



**Note:**  
The SAFETY STOP button functionality can be disabled in the Supervisor menu. **Figure 6-14** shows the state of the button for the menu options (left to right) Enabled, Disabled-ON and Disabled-OFF.



**Figure 6-14: Safety Stop Button Options (left to right) Enabled, Disabled-ON, Disabled-OFF**

There are two Safety Stop mode symbols that can be displayed in the Sensor window.



Safety stop – optical protection is active.



Safety stop – optical protection is muted.

### 6.7.1 Exiting Safety Stop Mode

To turn off Safety Stop mode, press the SAFETY STOP button when the clamp is open. If the clamp is not open, the Status window will display the message Open clamp to enable button function. The Mode Select screen will again appear as shown in **Figure 6-8**.

## 6.8 Jorns Twinmatic - Automatic Light Curtain Switching

Selected Jorns Twinmatic folding machines include a factory integrated light curtain that enables the independent activation of the FoldGuard laser guarding and the machine light curtain.

The FoldGuard system automatically activates/deactivates the laser guarding function based on the light curtain obstruction status. When the light curtain is clear, the laser guarding is automatically deactivated. When the machine operator steps inside the light curtain protective field, the system automatically activates the laser guarding function to provide point-of-operation protection for the clamping operation while the machine is being manually operated.



### Note:

This feature is designed for use with selected Jorns Twinmatic models only. Contact your FoldGuard dealer or email [customerservice@lazersafe.com](mailto:customerservice@lazersafe.com) for further information.

### 6.8.1 System Start-up

On power-up, the automatic switching function is deactivated, and the operator must first follow the HMI prompts to perform the FoldGuard start-up test and set the mute-point, as described in **Sections 6.1- 6.3**. Once the mute-point has been set, the automatic switching function is initiated, and the active guarding system will be determined by the status of the light curtain.

### 6.8.2 Automatic Switching Function

While the light curtain remains unobstructed FoldGuard automatically disables laser guarding and the light curtain protection is active. The HMI displays the message **Light Curtain Active**.

If the light curtain protective field is obstructed while the machine is running an automatic cycle, the cycle will stop and the operator must clear the obstruction and press the light curtain reset button before the machine cycle can resume.

If the light curtain remains obstructed the FoldGuard system automatically activates the laser guarding and the HMI displays the message **NORMAL MODE - Ready to Clamp**. In this instance, the CNC automatically deactivates the light curtain protection, and the machine can now be manually operated using the foot pedal. The FoldGuard laser guarding will function as described in **Section 3.4**, and the machine controller will force a safety stop (at an opening of 15mm) on each clamp closing cycle.



### Note:

Note that when operating the machine with laser guarding active the safety stop is initiated by the Jorns CNC, and **not** by the FoldGuard system. It is not possible to disable the safety stop function via the User Interface or the CNC.

To return to the automatic cycle, the operator must move out of the light curtain protective field and press the light curtain reset button. The reset button will then illuminate to indicate that the light curtain is active. The FoldGuard system then automatically disables the laser guarding function, and the HMI displays the message **Light Curtain Active**.

## 7 User and Supervisor Menus

The Menu screen gives access to the menus that are used to configure the way that the FoldGuard system operates. There are three levels of access to the menu system; User, Supervisor and System. To access the Menu screen press the **MENU** button in the Main screen.

The User level menu does not require an access code, and can be accessed by anyone operating the machine.

The Supervisor level menu requires an access code. This menu contains parameters that configure how the FoldGuard system and the User Interface Panel operate. This menu should only be accessible to suitably trained and authorized personnel.

The System menu requires an access code. (This is the highest level access code, and can also be used to access the Supervisor level menu). This menu contains machine/site specific parameters that are set during the installation of the FoldGuard Folding Machine Guarding System. The System menu is **not** described in this document.



Figure 7-1: Menu Screen

Label	Button Function
	This leaves the Menu screen and returns to the Main screen. See <b>Figure 5-2</b> for an overview of the menu system.
USER MENU	This accesses the User menu. No access code is required.
SUPERVISOR MENU	This accesses the Supervisor menu. An access level of Supervisor or System is required.
SYSTEM MENU	This accesses the System menu. An access level of System is required.
USER GUIDES	This accesses instructional guides on the operation of the FoldGuard system. No access code is required.

Table 7-1: Menu Screen Buttons



**Note:**

When any menu screen is selected, the safety application running on the Safety Controller turns off the enable outputs, and the machine cannot run. If the foot pedal is pressed, the LCD display on the Safety Controller will show the Condition Code **40A1**.

Once a menu has been selected the parameters can be navigated, selected and edited. The parameters are stored in non-volatile memory that is maintained even when the FoldGuard system is powered down.



**Warning:**  
**The System menu does not contain any user configurable parameters. System menu parameters must only be configured by trained and qualified FoldGuard installers. Setting incorrect parameter values in the System menu may render your machine inoperable.**

### 7.1.1 Selecting Menu Parameters

This section explains how to select and change the parameters in the Parameter List. For all of the menus (User, Supervisor and System) the parameters are navigated using the FoldGuard buttons, as shown in **Figure 7-2** and **Table 7-2**. The arrow buttons step through the parameter list; the parameter is selected by pressing the ENTER button.



**Note:**  
 Lists and values that are navigated using arrow keys always appear as loops. When the end of the list is reached, the next button press will return the screen to the start of the list.



**Figure 7-2: Menu Parameter Screen**

Label	Button Function
	This leaves the Parameter List and returns to the Menu screen. See <b>Figure 5-2</b> for an overview of the menu system.
	This changes the displayed parameter to the <b>next</b> parameter in the list (Parameter 0 → Parameter 1 → Parameter 2 etc.)
	This changes the displayed parameter to the <b>previous</b> parameter in the list. (Parameter 2 → Parameter 1 → Parameter 0 etc.)
ENTER	This selects the displayed item.

**Table 7-2: User/Supervisor/System Menu Buttons**

There are two types of parameters:

- **Options.** The value for the parameter can be selected from a list of options.
- **Numbers.** The parameter takes a numerical value between 0 and 9999.

### 7.1.2 Setting Option Parameters

Option parameters are navigated in the same way as menus, using the buttons described in **Figure 7-2** and **Table 7-2**. The arrow buttons step through the list of options; the desired option is then selected by pressing the ENTER button. When the ENTER button is pressed the value is stored in the FoldGuard system’s non-volatile memory, and the User Interface returns to the parameter list. Changes can be abandoned at any time by pressing the ↶ button.

### 7.1.3 Setting Numeric Parameters

Some parameters (such as access codes) require numeric values to be entered by the user. The numeric parameters are always displayed as four digits, ranging from 0000 to 9999. The Parameter screen also displays the name of the parameter, the units (typically millimetres or milliseconds) and the allowable range of parameter value.

The digit to be changed is underlined by a cursor starting with the left-most digit (i.e. the digit ‘1’ in **Figure 7-3** below). The ▲ ▼ buttons are pressed to increment or decrement the value of the underlined digit. Once the digit has been changed, the ► button is used to select the next digit, which is then underlined by the cursor.

This is continued until the parameter is set to the desired value. When the ENTER button is pressed the value is stored in non-volatile memory, and the FoldGuard User Interface returns to the parameter list. Changes can be abandoned at any time by pressing the ↶ button.

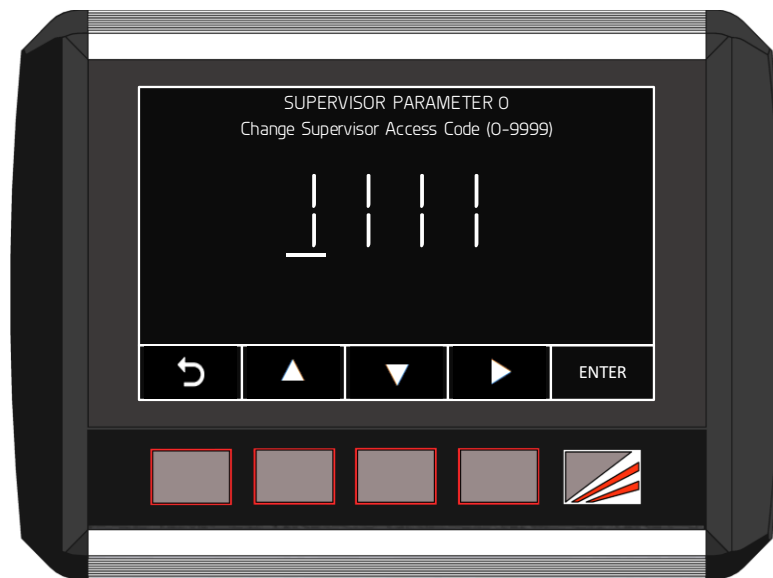

Figure 7-3: Numeric Parameter Screen

Label	Button Function
↶	This leaves the Parameter and returns to the Parameter List. See <b>Figure 5-2</b> for an overview of the menu system.
▲	Increments the selected digit i.e. 0→1→2 etc.
▼	Decrements the selected digit i.e. 0→9→8 etc.
►	Moves the cursor to the right to select the next digit to be changed. After the last digit, the cursor will loop back to the first digit.
ENTER	This stores the parameter in non-volatile memory, and returns to the Parameter list.

Table 7-3: Numeric Parameter Screen Buttons



**Note:**

The FoldGuard system will not allow a value to be entered which is outside of the allowable range for that parameter. The valid range of values is displayed next to the parameter's name in the Parameter screen (ignore the units). If an attempt is made to exceed the valid range, an Entry out of range message is displayed, and the value will not be saved.

## 7.2 User Menu

The user menu does not have access control, and can be accessed by anyone.

### 7.2.1 Parameter 0 – Buzzer On/Off

This parameter sets the behaviour of the buzzer.

- **ENABLED.** The buzzer will sound on every button press.
- **DISABLED.** The buzzer will never sound.

Use the ▲ ▼ buttons to navigate the options. Changes can be abandoned at any time by pressing the ↶ button. When the desired option has been selected, press the ENTER button, the value will be written into the FoldGuard system's non-volatile memory, and the system will return to the parameter list.

## 7.3 Supervisor Menu

The Supervisor menu is password protected. When the SUPERVISOR MENU button is pressed, the operator is prompted to enter the Supervisor level access code, as shown in **Figure 7-4**. This is a numeric parameter as described in **Section 7.1.3**, and shown in **Figure 7-3**.

**Note:**

The factory default supervisor access code is 1111. This should be changed as soon as the system is installed. If the Supervisor password is lost, contact Lazer Safe Customer Support or your local supplier for assistance.



**Figure 7-4: Supervisor Menu Access Screen**

If an attempt to enter an access code fails, the message Access code incorrect. Try again is displayed. There is no limit to the number of attempts that can be made.

### 7.3.1 Parameter 0 – Supervisor Access Code

This parameter sets the value of the Supervisor level access code and can take any value from 0000 – 9999.



Use the ► button to navigate the digits, and the ▲▼ buttons to change the digit value. Changes can be abandoned at any time by pressing the ↶ button. When the desired digit has been set press the ENTER button, the value will be written into the FoldGuard system's non-volatile memory, and the system will return to the parameter list.

### 7.3.2 Parameter 1 – Field Muted Button Functionality

In the Mode Select screen the FIELD MUTED button is used to place the FoldGuard system into Field Muted mode. Field Muted mode disables the optical protection and restricts the maximum pressing speed to slow speed (if the machine is capable of slow speed, refer **Section 2.2**), as described in **Section 3.6**.



#### **Warning: NO OPTICAL PROTECTION IN FIELD MUTED MODE**

In Field Muted mode, the optical sensing is deactivated. Although FoldGuard engages the slow speed signal and forces a safety stop on each cycle, particular caution must still be exercised.

**The ability to select Field Muted mode is disabled by default, and can only be enabled by personnel who have access to the Supervisor menu of the HMI. This menu is password protected and should only be accessible to suitably trained and qualified personnel.**

This parameter has three options (also described in **Section 6.6**), that sets the functionality of the FIELD MUTED button.

- **ENABLED.** The button FIELD MUTED button is functional.
- **DISABLED-ON.** The FoldGuard system is permanently locked in Field Muted Mode.
- **DISABLED-OFF.** The button is disabled, and Field Muted mode cannot be selected.

Use the ▲▼ buttons to navigate the options. Changes can be abandoned at any time by pressing the ↶ button. When the desired option has been selected, press the ENTER button, the value will be written into the FoldGuard system's non-volatile memory, and the system will return to the parameter list.

### 7.3.3 Parameter 2 – Safety Stop Button Functionality

In the Mode Select screen the SAFETY STOP button is used to put the FoldGuard system into Safety Stop mode, as described in **Section 3.7**. This parameter has three options (as described in **Section 6.7**), that sets the functionality of the SAFETY STOP button.

- **ENABLED.** The button functions as normal.
- **DISABLED-ON.** The FoldGuard system is permanently locked in Safety Stop Mode.
- **DISABLED-OFF.** The button is disabled, and Safety Stop mode cannot be selected.

Use the ▲▼ buttons to navigate the options. Changes can be abandoned at any time by pressing the ↶ button. When the desired option has been selected, press the ENTER button, the value will be written into the FoldGuard system's non-volatile memory, and the system will return to the parameter list.

### 7.3.4 Parameter 3 – Safety Distance

The safety distance is the size of the clamp opening where a safety stop is performed. This value is measured in millimetres (mm), and can be set between 12 and 20mm (0012 - 0020 for the parameter screen value).

Use the ► button to navigate the digits, and the ▲▼ buttons to change each digit value. Changes can be abandoned at any time by pressing the ↶ button. When the desired digit has been set press the ENTER button, the value will be written into the FoldGuard system's non-volatile memory, and the system will return to the parameter list.

### 7.3.5 Parameter 4 – Language

The language displayed by the FoldGuard User Interface is set in the Language menu.

Use the ▲▼ buttons to navigate the options. Changes can be abandoned at any time by pressing the ↶ button. When the desired option has been selected, press the ENTER button, the value will be written into the FoldGuard system's non-volatile memory, and the system will return to the parameter list.

## 8 Operator Instruction and Demonstration

Installer Reference #: \_\_\_\_\_

Instructor's Name: \_\_\_\_\_ Company: \_\_\_\_\_

Signature: \_\_\_\_\_ Date: \_\_\_\_\_

Ensure that the responsible person - Operator, Foreman or Manager (whoever the company designates as responsible) reads and understands the manual (translate if necessary).

It is suggested that the manual be given to this person as the installation is started so they will have read the manual by the time the installation is completed.

### 8.1 Equipment Identification

Component	Model	Serial Number	Notes
Safety Controller	PCSS-A0/PGS-2		
Transmitter	LZS-2-FG		
Receiver	LZS-2-FG		
User I/F Panel	FoldGuard HMI		

### 8.2 Starting the System

Refer to **Sections 6.1** and **6.2** for a detailed description.

- Demonstrate and explain the start-up test. Demonstrate the stopping test during start-up and explain how it tests the safety stopping performance of the machine and either passes or shuts the machine down with an error. Explain the 24 hour test if the machine is run continually for 24 hours.
- Explain how the transmitter and receiver operate. Demonstrate how the receiver detects the laser in segments (using a 4 mm Allen key is usually convenient). Show how blocking the laser like this is indicated on the Safety Controller, the receiver LEDs and the User Interface Sensor window.

### 8.3 Slow Speed Operation

- Determine if the machine is capable of running in slow speed.
- If the machine is **NOT** capable of operating in slow speed, highlight the importance of the safety stop, and modify the instruction/demonstration accordingly.



#### **Warning: SLOW SPEED OPERATION**

Under certain circumstances FoldGuard will initiate slow speed.

**However, some folding machines are not capable of changing the closing speed of the clamp to slow speed. FoldGuard will allow the clamp to close at normal operating speed, but will always perform a safety stop before the clamp closes.**

The operator will have to release and press the foot pedal again to complete the clamping operation.

## 8.4 Mute Point Setting

Refer to **Section 6.3** and **Section 6.4** for a detailed description.

- **Highlight the purpose of the mute point.** Explain that the sensors detect obstructions until 6mm above the fixed lower clamp.
- **Get the operator to demonstrate setting and resetting the mute point.** Make sure the process outlined in **Section 6.3** and **Section 6.4** is understood.
- Ensure that it is understood that the mute point is set from the rear and middle detection zones of the sensors.
- Demonstrate if the folding machine is capable of running in slow speed (if the machine is capable of slow speed, refer **Section 2.2**).
- Explain that if the clamp is closed three times but there has been no attempt to set a mute point (the sensors have been positioned so that they are not obstructed by the clamp), a safety stop is enforced. The safety stop will continue until the sensors are obstructed and a mute point set.
- Explain that once the mute point has been set, an overtravel limit of between 6mm and 12mm (depending upon the machine installation) is enforced to ensure that the optical protection is set within limits.

## 8.5 Operation in Normal Mode

Refer to **Section 3.4** for a detailed description.

Refer to **Section 6.5** for selecting guard modes.

- Ensure that it is understood what happens when the system runs in Normal mode.
- **The process must be understood and demonstrated.**
- Ensure it is understood that the protecting laser field is muted after the first obstruction and that the Status window turns red to indicate this.

## 8.6 Hemming Mode

Refer to **Section 3.5** for detailed descriptions.

Refer to **Section 6.5** and for selecting/exiting Hemming mode

- Explain and demonstrate how this process is used when hemming.
- **Get the operator to select between Normal and Hemming modes themselves.**
- Explain that the mute point is retained when switching between Normal and Hemming mode. Also get them to change mute point in Hemming mode.
- In Hemming mode, make sure they understand that the middle and rear sensors are muted after an obstruction, but if the middle sensor is obstructed the laser will be muted for the remainder of the stroke.
- Explain the need for a confirmation pedal press at the beginning of each stroke.

## 8.7 Field Muted Mode

Refer to **Section 3.6** for detailed descriptions.

Refer to **Section 6.6** for selecting/exiting Field Muted mode.

- Explain that this mode is disabled by default when the system is started, and how to enable it. Make sure the operator is aware that a responsible person should have access to the password for enabling the field-muted mode button.
- Demonstrate this function and ensure the operator understands that the laser protection will be switched off, and the machine will only operate in slow speed (if the machine is capable of slow speed, refer **Section 2.2**) with a safety stop while being used in this mode.
- Explain that the system will monitor the stopping performance.
- Show how to switch back to Normal mode.

**Warning: NO OPTICAL PROTECTION IN FIELD MUTED MODE**

In Field Muted mode, the optical sensing is deactivated. Although FoldGuard engages the slow speed signal (if the machine is capable of slow speed, refer **Section 2.2**) and forces a safety stop on each cycle, particular caution must still be exercised.

**The ability to select Field Muted mode is disabled by default, and can only be enabled by personnel who have access to the Supervisor menu of the HMI. This menu is password protected and should only be accessible to suitably trained and qualified personnel.**

## 8.8 Safety Stop Mode

Refer to **Section 3.7** for a detailed description.

Refer to **Section 6.7** for selecting/exiting Safety Stop mode.

- Explain and demonstrate the Safety Stop function.
- Explain that this mode is forced in Field Muted mode.
- Ensure the operator understands that there is no optical protection below the safety stop.

**Warning: NO PROTECTION BELOW SAFETY STOP POSITION**

Under certain circumstances the FoldGuard system will initiate a safety stop, and stop the clamp at the safety height (programmed in the System menu, refer **Section 7.3.4**).

**When the foot pedal is released and pressed again the clamp will close with the optical protection disabled. Particular caution must be exercised below the safety stop position.**

**Warning: NO PROTECTION BELOW SAFETY STOP POSITION**

Under certain circumstances the FoldGuard system will initiate a safety stop, and stop the clamp at the safety height (programmed in the System menu, refer **Section 7.3.4**).

**When the foot pedal is released and pressed again the clamp will close with the optical protection disabled. Particular caution must be exercised below the safety stop position.**

## 8.9 Setting the Laser Position

Refer to **Section 4** and *Lazer Safe FoldGuard Folding Machine Guarding System Alignment Guide (LS-CS-M-051)* for a detailed description on laser alignment.

- Demonstrate how the alignment cards are used to check the distance of the laser from the clamp ensuring that it is parallel.
- Show how the receiver sensor status can be viewed by the indicator LEDs on the Safety Controller, indicator LEDs on the receiver, and in the Sensor window of the User Interface Panel.
- Explain that if the transmitter and receiver are not correctly aligned, the mute point can be inaccurately detected when clamping and that error conditions can be generated that will prevent normal operation.

## 8.10 Running the System

- **Have the operator perform each of the main functions.**
- Using each mode of the system have the operator bend some test pieces of material and also making sure to utilise the Hemming.
- Ensure the operator is aware of each mode they are in, and the different Status/Action/Sensor windows in the FoldGuard panel display.

## 8.11 Customer Sign Off – Training Completed

Company Name: \_\_\_\_\_

Date: \_\_\_\_\_

Names of Company Representatives:

Signatures of Company Representatives:

\_\_\_\_\_

\_\_\_\_\_

\_\_\_\_\_

\_\_\_\_\_

\_\_\_\_\_

\_\_\_\_\_

\_\_\_\_\_

\_\_\_\_\_

\_\_\_\_\_

\_\_\_\_\_

\_\_\_\_\_

\_\_\_\_\_

## 9 Maintenance

---

### 9.1 Transmitter & Receiver

To maintain the transmitter and receiver, the filter window on both units should be regularly inspected to ensure they are free from finger prints, grease, dirt and scratches. The filter window should be replaced if it is damaged in any way.

Clean the transmitter and receiver windows with a weak solution of soap or detergent and lukewarm water. Do not use window cleaning sprays, scouring compounds, acetone, alcohol, gasoline, benzene, carbon tetrachloride or lacquer thinner to clean the window.

1. Dampen a soft, non-abrasive cloth or chamois with the cleaning solution, wring out any excess liquid.
2. Wipe the windows of the transmitter and receiver clean.
3. Dry the windows with a soft, non-abrasive cloth or chamois.

## 10 Glossary of Terms

Term	Description
Bending Apron	The lower part of the folding machine that move up to fold the material. The swing beam.
Clamp	The moving part of the folding machine that holds the material being bent.
Condition code	Status information from the PGS-2 displayed as a four digit hexadecimal number (0-9, A-F)
Crawl speed	The slow speed of the clamp
Danger zone	The point where any part of the body may be trapped between tools
Field muted mode	Operating mode of the FoldGuard where the protective laser field is turned off and the closing of the tools is possible in safe speed only.
Hemming mode	Operating mode of FoldGuard when some of the sensor zones are deactivated to allow hemming operations.
HMI	Human Machine Interface (i.e. the User Interface Panel)
Sensor A	The lower laser of the LSZ-2-FG
Sensor B	The upper laser of the LZS-2-FG
Mute	Deactivation of the protective laser field
Mute point	The point where the optical protection is deactivated
N/C	Normally closed contact
N/O	Normally open contact
Normal mode	Default operating mode of the FoldGuard
Opening	The distance between the upper and lower clamp
Open clamp	Increase the opening, retract the pressing beam
Optical Protection	Lazer Safe laser guards
Overtravel	The distance the clamp is allowed to travel past the calculated clamping point
Safety Stop	Operating mode where the clamp is stopped at the safety height
Stopping distance / overrun	The distance the tools continue to close before coming to a stop when a stop command is issued.
Swing beam	See Bending Apron